

Annex (1) – Regarding the Standard Specifications for Vehicles

Attached to Cabinet Resolution No. (42) of 2021

Regarding the UAE Regulation on Hydrogen-Fueled Vehicles

No.	Standard No.	Standard Title
1	UAE.S GSO 36	Motor Vehicle – Methods of test for Impact Strength – Part 1: Frontal Impact
2	UAE.S GSO 37	Motor Vehicle – Methods of test for Impact Strength – Part 2: Rear Impact
3	UAE.S GSO 38	Motor Vehicle – Methods of test for Impact Strength – Part 3A: Side Impact
4	UAE.S GSO 39	Motor Vehicle – Methods of test for Impact Strength – Part 4: Roof Strength
5	UAE.S GSO 40	Motor Vehicle – Impact Strength
6	UAE.S GSO 41	Motor Vehicle – Front and Rear Exterior Protection Devices for Passenger Cars (Bumpers etc.) and its Methods of Test
7	UAE.S GSO 42	Motor Vehicle: General Requirements
8	UAE.S GSO 48	Motor Vehicle: Conformity Certificates
9	UAE.S GSO 51	Passenger Car Tyres – Part 1: Nomenclature, Designation, Dimensions, Load Capacities and Inflation Pressures
10	UAE.S GSO 52	Passenger Car Tyres – Part 2: General Requirements
11	UAE.S GSO 53	Passenger Car Tyres – Part 3: Methods of Test
12	UAE.S GSO 96	Motor Vehicles – Methods of Testing of Safety Belt
13	UAE.S GSO 97	Motor Vehicles - Safety Belts
14	UAE.S GSO 98	Motor Vehicles – Flammability of Interior Materials and Testing Methods
15	UAE.S GSO 99	Road Vehicles – Sound Signalling Devices – Technical Specifications
16	UAE.S GSO 279**	Car Upholstery – Testing Methods of Fabric for Car Seats
17	UAE.S GSO 280**	Car Upholstery – Fabric for Seats

18	UAE.S GSO 289**	Road Vehicles – Retro Reflective Number Plates and its Methods Test
19	UAE.S GSO 290	Instruction Manual for Appliances Instruments and Equipment
20	UAE.S GSO 419	Motor Vehicles – Methods of Testing for Door Locks and Door Hinges
21	UAE.S GSO 420	Motor Vehicles – Door Locks and Door Hinges
22	UAE.S GSO 421	Motor Vehicles – Methods of Testing of Rear-view Mirrors
23	UAE.S GSO 422	Motor Vehicles – Rear-view Mirrors
24	UAE.S GSO 645	Multi-Purpose Vehicles, Trucks, Buses and Trailers Tyres – Part 1: Nomenclature, Designation, Dimensions, Load Capacities and Inflation Pressures
25	UAE.S GSO 646	Multi-Purpose Vehicles, Trucks, Buses and Trailers Tyres: Part 2: Method of Test
26	UAE.S GSO 647	Multi-Purpose Vehicles, Trucks, Buses and Trailers Tyres: Part 3: General Requirements
27	UAE.S GSO 971**	Motor Vehicles – Periodic Technical Inspection Manual
28	UAE.S GSO 1052*	Motor Vehicles Tyres – Temporary Use Spare wheel/Tyres and Their Methods of test
29	UAE.S GSO 1053	Motor Vehicles – Protection Against Theft
30	UAE.S GSO 1503	Motor Vehicles – Head Lamps Safety Requirements.
31	UAE.S GSO 1598	Motor Vehicles – Head Restraints and Their Methods of test
32	UAE.S GSO 1625*	Motor Vehicles – Speed Limiters- Part 2: Technical Requirements
33	UAE.S GSO 1626*	Motor Vehicles – Speed Limiters- Part 3: Methods of test
34	UAE.S GSO 1677	Motor Vehicles – Laminated Safety Glass
35	UAE.S GSO 1707	Motor Vehicles – Methods of test for Impact Strength- Part 3B: Moving Barrier Side Impact (In accordance to Us standards)
36	UAE.S GSO 1708	Motor Vehicles- Methods of test for Impact Strength- Part 3C: Moving Barrier Side Impact (In accordance to European standards)
37	UAE.S GSO 1709*	Motor Vehicles – Child Restraint Systems
38	UAE.S GSO 1710*	Motor Vehicles – Methods of Testing of Child Restraint

39	UAE.S GSO 1711*	Motor vehicles – Speed Limiters- Part 1: General requirements, Equipment Inspection, Certification and type approval
40	UAE.S GSO 1780	Motor Vehicles – Vehicle Identification Number (VIN) – Requirements
41	UAE.S GSO 1781	Motor Vehicles – World Manufacturer Identifier
42	UAE.S GSO 1782	Motor Vehicles – Vehicle Identification Number (VIN) – Location and attachment
43	UAE.S GSO 1783	Passenger Car Tyres – Tread wear, Traction and Temperature-Resistance Grading
44	UAE.S GSO 1784	Passenger Car Tyres – Method of Testing of tyre Temperature Resistance Grading
45	UAE.S GSO ISO 3537	Motor Vehicles- Safety Glazing Materials- Mechanical Tests
46	UAE.S GSO ISO 3538	Road Vehicles- Safety Glasses- Test Methods for Optical Properties
47	UAE.S GSO ISO 6311**	Motor Vehicles- Methods of Testing Brake Linings- Part 1: Internal Shear Strength of Lining Material.
48	GSO-ECE-13H	Motor Vehicles: Braking System of Passenger Cars and Multi-Purpose Vehicles
49	GSO-ECE-13H-1	Motor Vehicles: Methods of Test for Braking System- Part 1: Braking Performance
50	GSO-ECE-13H-2	Motor Vehicles: Methods of Test for Braking System- Part 2: Determination of Capacity of Energy Storage Devices
51	GSO-ECE-13H-3	Motor Vehicles: Methods of Test for Braking System- Part 3: Determination of Distribution of Braking among the Axles of Vehicles
52	GSO-ECE-13H-4	Motor Vehicles: Methods of Test for Braking System- Part 4: Determination of Function of Anti-Lock Systems
53	GSO-ECE-13H-5	Motor Vehicles: Methods of Test for Braking System- Part 5: Determination of Performance of Brake Lining Using Inertia

		Dynamometer
54	GSO-ECE-13H-6	Motor Vehicles: Methods of Test for Braking System- Part 6: Determination of Coefficient of Adhesion
*	<i>Applicable for certification if provided or the vehicle is designed for.</i>	
**	<i>Not applicable for Certification.</i>	

**Annex (2) – Regarding the Standard Specifications for Hydrogen Vehicles
Attached to Cabinet Resolution No. (42) of 2021
Regarding the UAE Regulation on Hydrogen-Fueled Vehicles**

Standard No.	Standards Title
Vehicle Fuel System	
UAE.S ISO 17268	Compressed hydrogen surface vehicle refuelling connection devices
UAE.S ISO 23273-1	Fuel cell road vehicles- Safety specification- Part 1: Vehicles functional safety;
UAE.S ISO 23273-2	Fuel cell road vehicles- Safety specifications- Part 2: Protection against hydrogen hazards for vehicles fuelled with compressed hydrogen
UAE.S ISO 14687	Hydrogen fuel quality- Product specification
Storage System	
EU Regulation 406/2010	Implementing of type-approval of hydrogen-powered motor vehicles
UAE.S ISO 13985:2006	Liquid Hydrogen – Land Vehicle Fuel Tanks
UAE.S ISO 15869:2009	Gaseous Hydrogen and Hydrogen Blends- Land Vehicle Fuel Tanks (Technical Specification)
Electric Safety Regulations	
UAE.S ECE R 100	The approval of vehicles with regard to specific requirements for the electric power train
UAE.S FMVSS 305	Electric-Powered Vehicles: Electrolyte Spillage and Electrical Shock Protection
UAE.S ISO 23273-3	Fuel cell road vehicles- Safety specification- Part 3: Protection of persons against electric shock;
UAE.S ISO 19880-3:2018	Gaseous hydrogen- Fuelling stations- Part 3: Valves

UAE.S ISO 19880-1:2020	Gaseous hydrogen- Fuelling stations- Part 1: General requirements
------------------------	---

Note: The FMVSS Specifications are accepted as an equivalent Specifications to the approved Specification.

Annex (3) – Regarding the UAE Technical Requirements for Hydrogen Vehicles

Attached to Cabinet Resolution No. (42) of 2021

Regarding the UAE Regulation on Hydrogen-Fueled Vehicles (Technical Regulation on Hydrogen-Fueled Vehicles)

1. Scope

This regulation applies to all hydrogen-fueled vehicles with a gross vehicle mass (GVM) of 4.500 kilograms or less and a speed not less than 25 Km/h.

2. Definitions

For the purpose of this regulation, the following definitions shall apply:

- 2.1 "*Active driving possible mode*" is the vehicle mode when application of pressure to the accelerator pedal (or activation of an equivalent control) or release of the brake system causes the electric power train to move the vehicle.
- 3.2 "*Automatic disconnect*" is a device that, when triggered, conductively separates the electrical energy sources from the rest of the high voltage circuit of the electrical power train.
- 3.3 "*Burst-dis*" is the non-reclosing operating part of a pressure relief device which, when installed in the device, is designed to burst at a predetermined pressure to permit the discharge of compressed hydrogen.
- 3.4 "*Check valve*" is a non-return valve that prevents reverse flow in the vehicle fuel line.
- 3.5 "*Concentration of hydrogen*" is the percentage of the hydrogen moles (or molecules) within the mixture of hydrogen and air (Equivalent to the partial volume of hydrogen gas).
- 3.6 "*Container*" (for hydrogen storage) is the component within the hydrogen storage system that stores the primary volume of hydrogen fuel.
- 3.7 "*Conductive connection*" is the connection using contractors to an external power supply when the rechargeable energy system (REESS) is charged.
- 3.8 "*Coupling system*" for charging the rechargeable energy storage system (REESS) is the electrical circuit used for charging the REESS from an external electric power supply

including the vehicle inlet.

- 3.9 "*Date of removal from service*" is the date (month and year) specified for removal from service.
- 3.10 "*Date of manufacture*" (of a compressed hydrogen container) is the date (month and year) of the proof pressure test carried out during manufacture.
- 3.11 "*Direct contact*" indicates the contact of persons with high voltage live parts.
- 3.12 "*Enclosed or semi-enclosed spaces*" indicates the special volumes within the vehicle (or the vehicle outline across openings), that are external to the hydrogen system (storage system, fuel cell system and Fuel flow management system) and its housing (if any) where hydrogen may accumulate (and thereby pose a hazard), as it may occur in the passenger compartment, luggage compartment, cargo compartment and space under the hood.
- 3.13 "*Enclosure*" is the part enclosing the internal units and providing protection against any direct contact.
- 3.14 "*Electric energy conversion system*" is a system (e.g. fuel cell) that generates and provides electrical power for vehicle propulsion.
- 3.15 "*Electric power train*" is the electrical circuit which may include the traction motor(s), and may also include the REESS, the electrical power conversion system, the electronic converters, the traction motors, the associated wiring harness and connectors and the coupling system for charging the REESS.
- 3.16 "*Electrical chassis*" is a set of conductive parts electrically linked together, whose electrical potential is taken as reference.
- 3.17 "*Electrical circuit*" is an assembly of connected high voltage live parts that is designed to be electrically energized in normal operation.
- 3.18 "*Electrical isolation*" is the electrical resistance between a vehicle high voltage bus source and any vehicle conductive structure.
- 3.19 "*Electrical protection barrier*" is the part providing protection against direct contact with live parts from any direction of access.
- 3.20 "*Electronic converter*" is a device capable of controlling and/or converting electric power for propulsion.
- 3.21 "*Exhaust point of discharge*" is the geometric centre of the area where fuel cell purged

gas is discharged from the vehicle.

- 3.22 "*Exposed conductive part*" is the conductive part that can be touched under the provisions of the IPXXB protection degree and becomes electrically energized under isolation failure conditions. This includes parts under a cover that can be removed without using tools.
- 3.23 "*External electric power supply*" is an alternating current (AC) or direct current (DC) that provides electric power outside of the vehicle.
- 3.24 "*Fuel cell system*" is a system containing the fuel cell stack(s), air processing system, fuel flow control system, exhaust system, thermal management system and water management system.
- 3.25 "*Fuelling receptacle*" is the equipment to which a fuelling station nozzle attaches to the vehicle and through which fuel is transferred to the vehicle. The fuelling receptacle is used as an alternative to a fuelling port.
- 3.26 "*High voltage*" is the classification of an electric component or circuit, if its maximum working voltage is greater than 60 V and less than or equal to 1500 V of direct current (DC), or greater than 30 V and less than or equal to 1000 V of alternating current (AC).
- 3.27 "*High Voltage Bus*" is the electrical circuit, including the coupling system, for charging the REESS that operates on high voltage.
- 3.28 "*Hydrogen-fuelled vehicle*" indicates any motor vehicle that uses compressed gaseous or liquefied hydrogen as a fuel to propel the vehicle, including fuel cell and internal combustion engine vehicles. Hydrogen fuel for passenger vehicles is specified in UAE.S ISO 14687 and SAE J2719.
- 3.29 "*Hydrogen storage system*" indicates a pressurized container, pressure relief devices (PRDs) and shut off device that isolate the stored hydrogen from the remainder of the fuel system and the environment.
- 3.30 "*Indirect contact*" is the contact of persons with exposed conductive parts.
- 3.31 "*Live parts*" is the conductive part intended to be electrically energized in normal use.
- 3.32 "*Luggage compartment*" is the space in the vehicle for luggage accommodation, bounded by the roof, hood, floor, side walls, as well as by the electrical barrier and enclosure provided for protecting the power train from direct contact with live parts, being

separated from the passenger compartment by the front bulkhead or the rear bulkhead.

- 3.33 "*Liquefied hydrogen storage system*" indicates liquefied hydrogen storage container(s) PRDs, shut off device, a boil-off system and the interconnection piping (if any) and fittings between the above components.
- 3.34 "*Lower flammability limit (LFL)*" is the lowest concentration of fuel at which a gaseous fuel mixture is flammable at normal temperature and pressure. The lower flammability limit for hydrogen gas in air is 4 per cent by volume (83 of the Preamble).
- 3.35 "*Maximum allowable working pressure (MAWP)*" is the highest gauge pressure to which a pressure container or storage system is permitted to operate under normal operating conditions.
- 3.36 "*Maximum fuelling pressure (MFP)*" is the maximum pressure applied to compressed system during fuelling. The maximum fuelling pressure is 125 per cent of the Nominal Working Pressure.
- 3.37 "*Nominal working pressure (NWP)*" is the gauge pressure that characterizes typical operation of a system. For compressed hydrogen gas containers, NWP is the settled pressure of compressed gas in fully fuelled container or storage system at a uniform temperature of 15 °C.
- 3.38 "*On-board isolation resistance monitoring system*" is the device that monitors isolation resistance between the high voltage buses and the electrical chassis.
- 3.39 "*Open type traction battery*" is a type of battery requiring liquid and generating hydrogen gas that is released into the atmosphere.
- 3.40 "*Passenger compartment (for electric safety assessment)*" is the space for occupant accommodation, bounded by the roof, floor, side walls, doors, outside glazing, front bulkhead and rear bulkhead-or rear gate-, as well as by the electrical barriers and enclosures provided for protecting the occupants from direct contact with live parts.
- 3.41 "*Pressure relief device (PRD)*" is a device that, when activated under specified performance conditions, is used to release hydrogen from a pressurized system and thereby prevent failure of the system.
- 3.42 "*Pressure relief valve*" is a pressure relief device that opens at a pre-set pressure level and can re-close.

- 3.43 "*Protection degree IPXXB*" indicates protection from contact with high voltage live parts provided by either an electrical barrier or an enclosure; it is tested using a Jointed Test Finger (IPXXB), as described in paragraph ANNEX 1.3.3.
- 3.44 "*Protection degree IPXXD*" indicates protection from contact with high voltage live parts provided by either an electrical barrier or an enclosure and tested using a Test Wire (IPXXD), as described in paragraph ANNEX 1.3.3.
- 3.45 "*Rechargeable energy storage system (REESS)*" is the rechargeable energy storage system that provides electric energy for electrical propulsion.
- 3.46 "*Rupture and burst*" both mean to come apart suddenly and violently, break open or fly into pieces due to the force of internal pressure.
- 3.47 "*Service disconnect*" is the device for deactivation of an electrical circuit when conducting checks and services of the REESS, fuel cell stack, etc.
- 3.48 "*Service life*" (of a compressed hydrogen container) indicates the time frame during which service (usage) is authorized.
- 3.49 "*Shut-off valve*" is a valve between the storage container and the vehicle fuel system that can be automatically activated; this valve defaults to "closed" position when not connected to a power source.
- 3.50 "*Single failure*" is a failure caused by a single event, including any consequential failures resulting from this failure.
- 3.51 "*Solid insulator*" is the insulating coating of wiring harnesses provided in order to cover and prevent the high voltage live parts from any direct contact. This includes covers for insulating the high voltage live parts of connectors and varnish or paint for the purpose of insulation.
- 3.52 "*Thermally-activated pressure relief device (TPRD)*" is a non-reclosing PRD that is activated by temperature to open and release hydrogen gas.
- 3.53 "*Type approval*" indicates a certification of a recognised body stating that prototype or pre-production samples of a specific vehicle, vehicle system or vehicle system component meet the relevant specified Performance standards, and that the final production versions also comply, as long as conformity of production is confirmed.
- 3.54 "*Vehicle fuel system*" is an assembly of components used to store or supply hydrogen

fuel to a fuel cell (FC) or internal combustion engine (ICE).

3.55 "*Working voltage*" is the highest value of an electrical circuit voltage root mean square (rms), specified by the manufacturer or determined by measurement, which may occur between any conductive parts in open circuit conditions or under normal operating condition. If the electrical circuit is divided by galvanic isolation, the working voltage is defined for each divided circuit, respectively.

4. Applicability of requirements

4.1 The requirements of paragraph 5. (Using test conditions and procedures in paragraph ANNEX 1.) Apply to all compressed hydrogen fuelled vehicles.

4.2 Crash test (frontal, side, rear and rollover) for compliance with section 5.2.2. should be according GSO 42.

4.3 The requirements of paragraph 5.3. Apply to all hydrogen-fuelled vehicles using high voltage.

5. Performance requirements

5.1 Compressed hydrogen storage system

This section specifies the requirements for the integrity of the compressed hydrogen storage system. The hydrogen storage system consists of the high pressure storage container and primary closure devices for openings into the high pressure storage container. Figure 1 shows a typical compressed hydrogen storage system.

Figure 1

Typical compressed hydrogen storage system

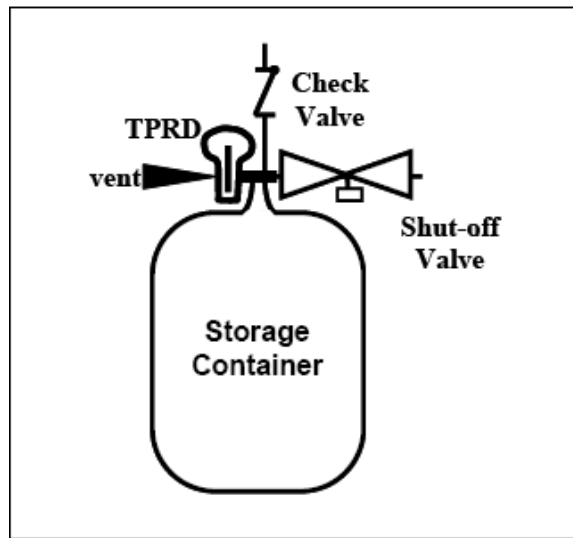

All new compressed hydrogen storage systems produced for on-road vehicle service shall have a NWP of 70 MPa or less and a service life of 15 years or less, and be capable of satisfying the requirements of paragraph 5.1.

The hydrogen storage system shall meet the performance test requirements specified in this paragraph.

The test elements within these performance requirements are summarized in Table 1. The corresponding test procedures are specified in paragraph ANNEX 1.

Table 1

Overview of performance qualification test requirements

5.1.1. Verification tests for baseline metrics
5.1.1.1. Baseline initial burst pressure
5.1.1.2. Baseline initial pressure cycle life
5.1.2. Verification test for performance durability (sequential hydraulic tests)
5.1.2.1 Proof pressure test
5.1.2.2. Drop (impact) test
5.1.2.3. Surface damage
5.1.2.4. Chemical exposure and ambient temperature pressure cycling tests

5.1.2.5. High temperature static pressure test
5.1.2.6 ANNEX 1. Extreme temperature pressure cycling
5.1.2.7. Residual proof pressure test
5.1.2.8. Residual strength Burst Test
5.1.3. Verification test for expected on-road performance (sequential pneumatic tests)
5.1.3.1 Proof pressure test
5.1.3.2. Ambient and extreme temperature gas pressure cycling test (pneumatic)
5.1.3.3. Extreme temperature static gas pressure leak/permeation test (pneumatic)
5.1.3.4. Residual proof pressure test
5.1.3.5. Residual strength burst test (hydraulic)
5.1.4. Verification test for service terminating performance in fire
5.1.5. Verification test for closure durability

5.1.1. Verification tests for baseline metrics

5.1.1.1. Baseline initial burst pressure

Three (3) new containers randomly selected from the design qualification batch of at least 10 containers, are hydraulically pressurized until burst (ANNEX 1.2.2.1. test procedure). The manufacturer shall supply documentation (measurements and statistical analyses) that establish the midpoint burst pressure of new storage containers, BP_o .

All containers tested shall have a burst pressure within ± 10 per cent of BP_o and greater than or equal to a minimum BP_{min} of 225 per cent NWP.

In addition, containers having glass-fibre composite as a primary constituent to have a minimum burst pressure than 350 per cent NWP.

5.1.1.2. Baseline initial pressure cycle life

Three (3) new containers randomly selected from the design qualification batch are hydraulically pressure cycled at $20 (\pm 5)^\circ\text{C}$ to 125 per cent NWP without: rupture for 22,000 cycles or until a leak occurs (ANNEX 1.2.2.2. test procedure). Leakage shall not occur within a number of Cycles, where the number of Cycles is set individually by each Contracting Party at 5,500, 7,500 or 11,000 cycles for a 15-year service life.

5.1.2. Verification tests for performance durability (Hydraulic sequential tests)

If all three pressure cycle life measurements made in 5.1.1.2. are greater than 11,000 cycles, or if they are all within ± 25 per cent of each other, then only one (1) container is tested in 5.1.2. Otherwise, three (3) containers are tested in 5.1.2.

A hydrogen storage container shall not leak during the following sequence of tests, which are applied in series to a single system and which are illustrated in Figure 2. At least one system randomly selected from the design qualification batch shall be tested to demonstrate the performance capability. Specifics of applicable test procedures for the hydrogen storage system are provided in ANNEX 1.2.3.

Figure 2

Verification test for performance durability (hydraulic)

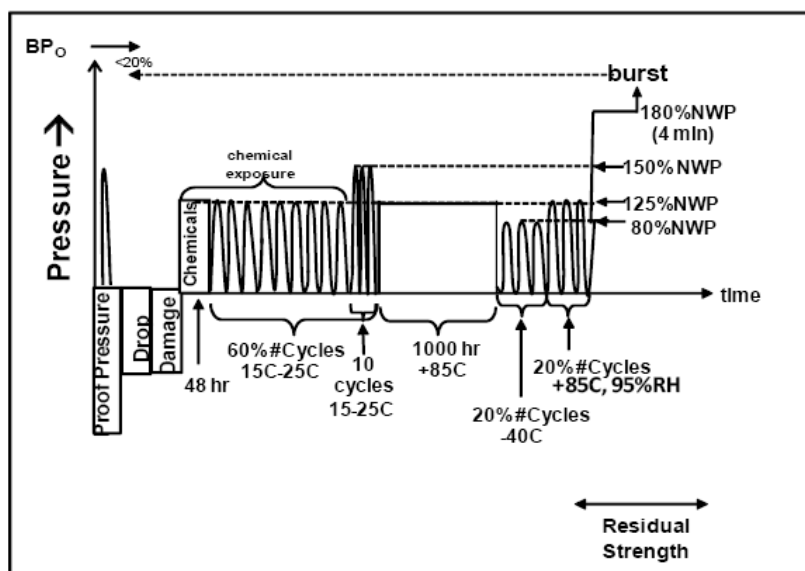

1.1.2.1. Proof pressure test

A storage container is pressurized to 150 per cent NWP and held for 30 sec (ANNEX 1.2.3.1. test procedure). A storage container that has undergone a proof pressure test in manufacture is exempt from this test.

1.1.2.2. Drop (impact) test

The storage container is dropped at several impact angles (ANNEX 1.2.3.2. test procedure).

1.1.2.3. Surface damage test

The storage container is subjected to surface damage (ANNEX 1.2.3.3. test procedure).

1.1.2.4. Chemical exposure and ambient-temperature pressure cycling test

The storage container is exposed to chemicals found in the on-road environment and pressure cycled to 125 per cent NWP at 20° (±5)°C for 60 per cent number of Cycles pressure cycles (ANNEX 1.2.3.4. test procedure). Chemical exposure is discontinued before the last 10 cycles, which are conducted to 150 per cent NWP.

1.1.2.5. High temperature static pressure test.

The storage container is pressurized to 125 per cent NWP at >85°C for 1,000 hr (ANNEX 1.2.3.5. test procedure).

1.1.2.6. ANNEX 1. Extreme temperature pressure cycling.

The storage container is pressure cycled at <-40°C to 80 per cent NWP for 20 per cent number of Cycles and at >+85°C and 95 per cent relative humidity to 125 per cent NWP for 20 per cent number of Cycles (ANNEX 1.2.2.2. test procedure).

1.1.2.7. Hydraulic residual pressure test. The storage container is pressurized to 180 per cent NWP and held 4 minutes without burst (ANNEX 1.2.3.1. test procedure).

1.1.2.8. Residual burst strength test

The storage container undergoes a hydraulic burst test to verify that the burst pressure is at least 80 per cent of the baseline initial burst pressure (BPo) determined in 5.1.1.1. (ANNEX 1.2.2.1. test procedure).

1.1.3. **Verification test for expected on-road performance (Pneumatic sequential tests)**

A hydrogen storage system shall not leak during the following sequence of tests, which are illustrated in figure 3. Specifics of applicable test procedures for the hydrogen storage system are provided in paragraph ANNEX 1.

Figure 3

Verification test for expected on-road performance (pneumatic/hydraulic)

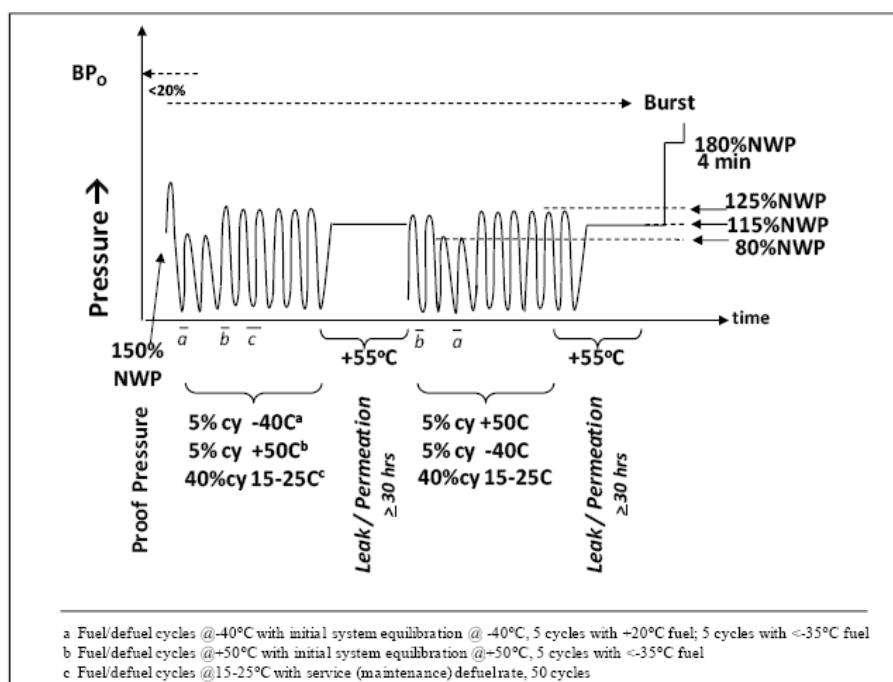

1.1.3.1. Proof pressure test

A system is pressurized to 150 per cent NWP for 30 seconds (ANNEX 1.2.3.1 test procedure). A storage container that has undergone a proof pressure test in manufacture is exempt from this test.

1.1.3.2. Ambient and extreme temperature gas pressure cycling test

The system is pressure cycled using hydrogen gas for 500 cycles (ANNEX 1.2.4.1. Test procedure).

- (a) The pressure cycles are divided into two groups: Half of the cycles (250) are performed before exposure to static pressure (5.1.3.3.) and the remaining half of the cycles (250) are performed after the initial exposure to static pressure (5.1.3.3.) and the remaining half of the cycles (250) are performed after the initial exposure to static pressure (5.1.3.3.) as illustrated in Figure 3;
- (b) The first group of pressure cycling 25 cycles are performed to 80 per cent NWP at <-40°C, then 25 cycles to 125 per cent NWP at >+50°C and 95 per cent relative humidity, and the remaining 200 cycles to 125 per cent NWP at 20 (±5)°C; The second group of pressure cycling 25 cycles are performed to 125 per cent NWP at >+50°C and 95 per

cent relative humidity, then 25 cycles to 80 per cent NWP at $<-40^{\circ}\text{C}$, and the remaining 200 cycles to 125 per cent NWP at $20 (\pm 5)^{\circ}\text{C}$;

- (c) The hydrogen gas fuel temperature is $<-40^{\circ}\text{C}$;
- (d) During the first group of 250 pressure cycles, five cycles are performed with fuel having a temperature of $+ 20 (\pm 5)^{\circ}\text{C}$ after temperature equilibration of the system at $<-40^{\circ}\text{C}$; five cycles are performed with Fuel having a temperature of $<-40^{\circ}\text{C}$; and five cycles are performed with fuel having a temperature of $<-40^{\circ}\text{C}$ after temperature equilibration of the system at $>50^{\circ}\text{C}$ and 95 per cent relative humidity;
- (e) Fifty pressure cycles are performed using a de-fuelling rate greater than or equal to the maintenance de-fuelling rate.

1.1.3.3. Extreme temperature static pressure leak/permeation test.

- (a) The test is performed after each group of 250 pneumatic pressure cycles in paragraph 5.1.3.2.;
- (b) The maximum allowable hydrogen discharge from the compressed hydrogen storage system is 46 ML/h/L water capacity of the storage system. (ANNEX 1.2.4.2. Test procedure);
- (c) If the measured permeation rate is greater than 0.005 mg/sec (3.6 Nml/min), a localized leak test is performed to ensure no point of localized external leakage is greater than 0.005 mg/sec (3.6 Nml/min) (ANNEX 1.2.4.3. test procedure).

1.1.3.4. Residual proof pressure test (hydraulic)

The storage container is pressurized to 180 per cent NWP and held 4 minutes without burst (ANNEX 1.2.3.1. test procedure).

1.1.3.5. Residual strength burst test (hydraulic)

The storage container undergoes a hydraulic burst to verify that the burst pressure is within 20 per cent of the baseline burst pressure determined in 5.1.1.1. (ANNEX 1.2.2.1. test procedure).

1.1.4. **Verification test for service terminating performance in fire**

This section describes the fire test with compressed hydrogen as the test gas.

A hydrogen storage system is pressurized to NWP and exposed to fire (ANNEX 1.2.5.1. test procedure). A temperature-activated pressure relief device shall release the contained

gases in a controlled manner without rupture.

1.1.5. Verification test for performance durability of primary closures

Manufacturers shall maintain records that confirm that closures that isolate the high pressure hydrogen storage system (the TPRD(s), check valve(s) and shut-off valve(s) shown in Figure 1) comply with the requirements described in the remainder of this Section.

The entire storage system does not have to be re-qualified (5.1.) if these closure components (components in Figure 1 excluding the storage container) are exchanged for equivalent closure components having comparable function, fittings, materials, strength and dimensions, and qualified for performance using the same qualification tests as the original components. However, a change in TPRD hardware, its position of installation or venting lines requires re-qualification with fire testing according to 5.1.4.

1.1.5.1. TPRD qualification requirements

Design qualification testing shall be conducted in finished pressure relief devices, which are representative of normal production. The TPRD shall meet the following performance qualification requirements:

- (a) Pressure cycling test (ANNEX 1.2. ANNEX 1.1.1.);
- (b) Accelerated life test (ANNEX 1.2. ANNEX 1.1.2.);
- (c) Temperature cycling test (ANNEX 1.2. ANNEX 1.1.3.);
- (d) Salt corrosion resistance test (ANNEX 1.2. ANNEX 1.1.4.);
- (e) Vehicle environment test (ANNEX 1.2. ANNEX 1.1.5.);
- (f) Stress corrosion cracking test (ANNEX 1.2. ANNEX 1.1. ANNEX 1.);
- (g) Drop and vibration test (ANNEX 1.2. ANNEX 1.1.7.);
- (h) Leak test (ANNEX 1.2. ANNEX 1.1.8.);
- (i) Bench top activation test (ANNEX 1.2. ANNEX 1.1.9.);
- (j) Flow rate test (ANNEX 1.2. ANNEX 1.1.10.);

1.1.5.2. Check valve and automatic shut-off valve qualification on requirements

Design qualification testing shall be conducted on finished check valves and shut-off valves which are representative of normal production. The valve units shall meet the following performance qualification requirements:

- (a) Hydrostatic strength test (ANNEX 1.2. ANNEX 1.2.1.);
- (b) Leak test (ANNEX 1.2. ANNEX 1.2.2.);
- (c) Extreme temperature pressure cycling test (ANNEX 1.2. ANNEX 1.2.3.);
- (d) Salt corrosion resistance test (ANNEX 1.2. ANNEX 1.2.4.);
- (e) Vehicle environment test (ANNEX 1.2. ANNEX 1.2.5.);
- (f) Atmospheric exposure test (ANNEX 1.2. ANNEX 1.2. ANNEX 1.);
- (g) Electrical tests (ANNEX 1.2. ANNEX 1.2.7.);
- (h) Vibration test (ANNEX 1.2. ANNEX 1.2.8.);
- (i) Stress corrosion cracking test (ANNEX 1.2. ANNEX 1.2.9.);
- (j) Pre-cooled hydrogen exposure test (ANNEX 1.2. ANNEX 1.2.10.);

5.1. ANNEX 1. **Labelling**

A label shall be permanently affixed on each container with at least the following information: name of the manufacturer, serial number, date of manufacture, NWP, type of fuel, and date of removal from service. Each container shall also be marked with the number of cycles used in the testing programme As per 5.1.1.2. Any label affixed to the container in compliance with this section shall remain in place and be legible for the duration of the manufacturer's recommended service life for the container. Date of removal from service shall not be more than 15 years after the date of manufacture.

1.2. **Vehicle fuel system**

This section specifies requirements for the integrity of the hydrogen fuel delivery system, which includes the hydrogen storage system, piping, joints, and components in which hydrogen is present.

5.2.1. In-use fuel system integrity

5.2.2. Fuelling receptacle requirements

5.2.1.1.1. A compressed hydrogen fuelling receptacle shall prevent reverse flow to the atmosphere. Test procedure is visual inspection.

5.2.1.1.2. Fuelling receptacle label A label shall be affixed close to the fuelling receptacle; for

instance, inside a refilling hatch, showing the following information: fuel type, NWP, date of removal from service of containers.

5.2.1.1.3. The fuelling receptacle shall be mounted on the vehicle to ensure positive locking of the fuelling nozzle. The receptacles shall be protected from tampering and the ingress of dirt and water (e.g. installed in a compartment which can be locked). Test procedure is by visual inspection.

5.2.1.1.4. The fuelling receptacle shall not be mounted within the external energy absorbing elements of the vehicle (e.g. bumper) and shall not be installed in the passenger compartment, luggage compartment and other places where hydrogen gas could accumulate and where ventilation is not sufficient. Test procedure is by visual inspection.

5.2.1.2. Over-pressure protection for the low pressure system (ANNEX 1.1. ANNEX 1. Test procedure) The hydrogen system downstream of a pressure regulator shall be protected against overpressure due to the possible failure of the pressure regulator. The set pressure of the overpressure protection device shall be lower than or equal to the maximum allowable working pressure for the appropriate section of the hydrogen system.

5.2.1.3. Hydrogen discharge systems

5.2.1.3.1. Pressure relief systems (ANNEX 1.1. ANNEX 1. Test procedure)

- (a) Storage system TPRDs. The outlet of the vent line, if present, for hydrogen gas discharge from TRD(s) of the storage system shall be protected by a cap;
- (b) Storage system TPRDs. The hydrogen gas discharge from TPRD(s) of the storage system shall not be directed:
 - (i) Into enclosed or semi-enclosed spaces;
 - (ii) Into or towards any vehicle wheel housing;
 - (iii) Towards hydrogen gas containers;
 - (iv) Forward from the vehicle, or horizontally (parallel to road) from the back or sides of the vehicle.
- (c) Other pressure relief devices (such as a burst disk) may be used outside the hydrogen storage system. The hydrogen gas discharge from other pressure relief devices shall

not be directed:

- (i) Towards exposed electrical terminals, exposed electrical switches or other ignition sources;
- (ii) Into or towards the vehicle passenger or cargo compartments;
- (iii) Into or towards any vehicle wheel housing;
- (iv) Towards hydrogen gas containers.

5.2.1.3.2. Vehicle Exhaust System (ANNEX 1.1.4. test procedure)

At the vehicle exhaust system's point of discharge, the hydrogen concentration level shall:

- (a) Not exceed 4 per cent average by volume during any moving three-second time interval during normal operation including start-up and shutdown;
- (b) And not exceed 8 per cent at any time (ANNEX 1.1.4. test procedure).

5.2.1.4. Protection against flammable conditions: single failure conditions

5.2.1.4.1. Hydrogen leakage and/or permeation from the hydrogen storage system shall not directly vent into the passenger, luggage, or cargo compartments, or to any enclosed or semi-enclosed spaces within the vehicle, that contains unprotected ignition sources.

5.2.1.4.2 Any single failure downstream of the main hydrogen shut off valve shall not result in any level of a hydrogen concentration in anywhere in the passenger compartment according to test procedure ANNEX 1.1.3.2.

5.2.1.4.3. If, during operation, a single failure results in a hydrogen concentration exceeding 2 ± 1.0 per cent by volume in air in the enclosed or semi-enclosed spaces of the vehicle, then a warning shall be provided (5.2.1. ANNEX 1.). If the hydrogen concentration exceeds 3 ± 1.0 per cent by volume in the air in the enclosed or semi-enclosed spaces of the vehicle, the main shutoff valve shall be closed to isolate the storage system. (ANNEX 1.1.3. test procedure).

5.2.1.5. Fuel system leakage the hydrogen fuelling line and the hydrogen system(s) downstream of the main shut off valve(s) shall not leak. Compliance shall be verified at NWP (ANNEX 1.1.5. test procedure).

5.2.1. ANNEX 1. Tell-tale signal warning to driver

The warning shall be given by a visual signal or display text with the following

properties:

- (a) Visible to the driver while in the driver's designated seating position with the driver's seat belt fastened;
- (b) Yellow in colour if the detection system malfunctions and shall be red in compliance with section 5.2.1.4.3;
- (c) When illuminated, shall be visible to the driver under both daylight and night time driving conditions;
- (d) Remains illuminated when 2 ± 1.0 per cent concentration or detection malfunction) exists and the ignition locking system is in the "On" ("Run") position or the propulsion system is activated.

5.2.2. Post-crash fuel system integrity

5.2.2.1. Fuel leakage limit

The volumetric flow of hydrogen gas leakage shall not exceed an average of 118 NL per minute for 60 minutes after the crash (ANNEX 1.1.1. test procedures).

5.2.2.2. Concentration limit in enclosed spaces

Hydrogen gas leakage shall not result in a hydrogen concentration in the air greater than 3 ± 1.0 per cent) by volume in the passenger, luggage and cargo compartments (ANNEX 1.1.2. test procedures). The requirement is satisfied if it is confirmed that the shut-off valve of the storage system has closed within 5 seconds of the crash and no leakage from the storage system.

5.2.2.3. Container Displacement

The storage container(s) shall remain attached to the vehicle at a minimum of one attachment point.

5.3. Electrical safety

5.3.1. Electrical Safety requirements - in-use

5.3.1.1. General

Paragraph 5.3.1. applies to the electric power train of fuel cell vehicles equipped with one or more traction motor(s) operated by electric power and not permanently connected to the grid, as well as their high voltage components and systems which are conductively

connected to the high voltage bus of the electric power train.

5.3.1.2. Requirements for protection against electric shock

5.3.1.2.1. Protection against electric shock

These electrical safety requirements apply to high voltage buses under conditions where they are not connected to external high voltage power supplies.

5.3.1.2.2. Protection against direct contact

The protection against direct contact with live parts shall comply with paragraphs 5.3.1.2.2.1. and 5.3.1.2.2.2. These protections (solid insulator, electrical protection barrier, enclosure, etc.) shall not be opened, disassembled or removed without the use of tools.

5.3.1.2.2.1. For protection of live parts inside the passenger compartment or luggage compartment, the protection degree IPXXD shall be provided.

5.3.1.2.2.2. For protection of live parts in areas other than the passenger compartment or luggage compartment, the protection degree IPXXB shall be satisfied.

5.3.1.2.2.3. Connectors

Connectors (including vehicle inlet) are deemed to meet this requirement if:

- (a) They comply with paragraphs 5.3.1.2.2.1. and 5.3.1.2.2.2. when separated without the use of tools; or
- (b) They are located underneath the floor and are provided with a locking mechanism; or
- (c) They are provided with a locking mechanism and other components shall be removed with the use of tools in order to separate the connector; or
- (d) The voltage of the live parts becomes equal or below DC GOV or equal or below AC 30V (rms) within 1 second after the connector is separated.

5.3.1.2.2.4. Service disconnect

For a service disconnect which can be opened, disassembled or removed without tools, it is acceptable if protection degree IPXXB is satisfied when it is opened, disassembled or removed without tools.

5.3.1.2.2.5. Marking

5.3.1.2.2.5.1. The symbol shown in Figure 4 shall appear on or near the REESS. The symbol background shall be yellow, the bordering and the arrow shall be black.

Figure 4

Marking of high voltage equipment



5.3.1.2.2.5.2. The symbol shall be visible on enclosures and electrical protection barriers, which, when removed, expose live parts of high voltage circuits. This provision is optional to any connectors for high voltage buses. This provision shall not apply to any of the following cases.

- (a) Where electrical protection barriers or enclosures cannot be physically accessed, opened, or removed; unless other vehicle components are removed with the use of tools;
- (b) Where electrical protection barriers or enclosures are located underneath the vehicle floor.

5.3.1.2.2.5.3. Cables for high voltage buses which are not located within enclosures shall be identified by having an outer covering with the colour orange.

5.3.1.2.3. Protection against indirect contact

5.3.1.2.3.1. For protection against electric shock which could arise from indirect contact, the exposed conductive parts, such as the conductive electrical protection barrier and enclosure, shall be conductively connected and secured to the electrical chassis with electrical wire or ground cable, by welding, or by connection using bolts, etc. so that no dangerous potentials are produced.

5.3.1.2.3.2. The resistance between all exposed conductive parts and the electrical chassis shall be lower than 0.1ohm when there is current flow of at least 0.2 amperes. Demonstrated by using one of the test procedures described in ANNEX 1.3.4. This requirement is satisfied if the galvanic connection has been established by welding. In case of doubts a measurement shall be made.

5.3.1.2.3.3. In the case of motor vehicles which are connected to the grounded external

electric power supply through the conductive connection, a device to enable the conductive connection of the electrical chassis to the earth ground shall be provided. The device shall enable connection to the earth ground before exterior voltage is applied to the vehicle and retain the connection until after the exterior voltage is removed from the vehicle.

Compliance to this requirement may be demonstrated either by using the connector specified by the car manufacturer, or by analysis (e.g. visual inspection, drawings etc.).

5.3.1.2.4. Isolation resistance monitoring system

5.3.1.2.4.1. In fuel cell vehicles, DC high voltage buses shall have an on-board isolation resistance monitoring system together with a warning to the driver if the isolation resistance drops below the minimum required value of 100 ohms/volt. The function of the on-board isolation resistance monitoring system shall be confirmed as described in ANNEX 1.3.2.

The isolation resistance between the high voltage bus of the coupling system for charging the REESS, which is not energized in conditions other than that during the charging of the REESS, and the electrical chassis need not to be monitored.

5.3.1.2.4.2. Electric power train consisting of separate DC or AC buses

If AC high voltage buses and DC high voltage buses are conductively isolated from each other, isolation resistance between the high voltage bus and the electrical chassis shall have a minimum value of 100 ohms/volt of the working voltage for DC buses, and a minimum value of 500 ohms/volt of the working voltage for AC buses. The measurement shall be conducted according to ANNEX 1.3.1.

5.3.1.2.4.3. Electric power train consisting of combined DC- and AC-buses

If AC high voltage buses and DC high voltage buses are galvanically connected, isolation resistance between the high voltage bus and the electrical chassis shall have a minimum value of 500 Ω /volt of the working voltage.

However, if all AC high voltage buses are protected by one of the two following measures, isolation resistance between the high voltage bus and the electrical chassis shall have a minimum value of 100 ohms/volt of the working voltage.

- (a) Double or more layers of solid insulators, electrical protection barriers or enclosures that meet the requirement in paragraph 5.3.1.2.3. independently, for example wiring harness;
- (b) Mechanically robust protections that have sufficient durability over vehicle service life such as motor housings, electronic converter cases or connectors.

5.3.1.2.4.4. Isolation resistance requirement for the coupling system for charging the REESS.

For the vehicle inlet intended to be conductively connected to the grounded external AC power supply and the electrical circuit that is conductively connected to the vehicle inlet during charging the REESS, the isolation resistance between the high voltage bus and the electrical chassis shall be at least 1M ohms when the charger coupler is disconnected. During the measurement, the REESS may be disconnected. The measurement shall be conducted according to ANNEX 1.3.1.

5.3.1.3. Functional safety

At least a momentary indication shall be given to the driver when the vehicle is in "active driving possible mode".

However, this provision does not apply under conditions where an internal combustion engine provides directly or indirectly the vehicle's propulsion power upon start up.

When leaving the vehicle, the driver shall be informed by a signal (e.g. optical or audible signal) if the vehicle is still in the active driving possible mode.

If the on-board REESS can be externally charged, vehicle movement by its own propulsion system shall be impossible as long as the connector of the external electric power supply is physically connected to the vehicle inlet.

This requirement shall be demonstrated by using the connector specified by the car manufacturer.

The state of the drive direction control unit shall be identified to the driver.

5.3.2. Electric safety requirements - post-crash

5.3.2.1. General

Fuel cell vehicles equipped with electric power train shall comply with the requirements of paragraphs 5.3.2.2. to 5.3.2.4. This can be met by a separate impact

test provided that the electrical components do not influence the occupant protection performance of the vehicle type as defined in the impact regulation. In case of this condition the requirements of paras. 5.3.2.2. to 5.3.2.4. shall be checked in accordance with the methods set out in ANNEX 1.3.5.

5.3.2.2. Protection against electric shock

After the impact at least one of the three criteria specified in paragraphs 5.3.2.2.1. to 5.3.2.2.3. shall be met.

If the vehicle has an automatic disconnect function, or device(s) that conductively divide the electric power train circuit during driving condition, at least one of the following criteria shall apply to the disconnected circuit or to each divided circuit individually after the disconnect function is activated. However criteria defined in 5.3.2.2.2. shall not apply if more than a single potential of a part of the high voltage bus is not protected under the conditions of protection degree IPXXB.

In the case that the test is performed under the condition that part(s) of the high voltage system are not energized, the protection against electric shock shall be proved by either 5.3.2.2.2. or 5.3.2.2.3. for the relevant part(s).

5.3.2.2.1. Absence of high voltage

The voltages V_b , V_1 and V_2 of the high voltage buses shall be equal or less than 30 VAC or 60 VDC within 60 seconds after the impact as specified in ANNEX 1.3.5. and ANNEX 1.3.5.2.2.

5.3.2.2.2. Isolation resistance

The criteria specified in the paragraphs 5.3.2.2.2.1. and 5.3.2.2.2.2. below shall be met. The measurement shall be conducted in accordance with paragraph ANNEX 1.3.5.2.3. of paragraph ANNEX 1.3.5.

5.3.2.2.2.1. Electrical power train consisting of separate DC- and AC-buses

If the AC high voltage buses and the DC high voltage buses are conductively isolated from each other, isolation resistance between the high voltage bus and the electrical chassis (R_i , as defined in paragraph ANNEX 1.3.5.2.3.) shall have a minimum value of 100. /volt of the working voltage for DC buses, and a minimum value of 500 /volt of the working voltage for AC buses.

5.3.2.2.2. Electrical power train consisting of combined DC- and AC-buses

If the AC high voltage buses and the DC high voltage buses are conductively connected they shall meet one of the following requirements:

- (a) Isolation resistance between the high voltage bus and the electrical chassis (R_i , as defined in paragraph ANNEX 1.3.5.2.3.) shall have a minimum value of 500 /volt of the working collage;
- (b) Isolation resistance between the high voltage bus and the electrical chassis (R_i , as defined in paragraph ANNEX 1.3.5.2.3.) shall have a minimum value of 100 volt of the working voltage and the AC bus meets the physical protection as described in 5.3.2.2.3.;
- (c) Isolation resistance between the high voltage bus and the electrical chassis (R_i , as defined in paragraph ANNEX 1.3.5.2.3.) shall have a minimum value of 100 l/volt of the working voltage and the AC bus meets the absence of high voltage as described in 5.3.2.2.1.

5.3.2.2.3. Physical protection

Individual Contracting Parties may elect to adopt the physical protection. For protection against direct contact with high voltage live parts, the protection degree IPXXB shall be provided.

In addition, for protection against electric shock which could arise from indirect contact, the resistance between all exposed conductive parts and electrical chassis shall be lower than 0.1 ohm when there is current flow of at least 0.2 amperes.

This requirement is satisfied if the galvanic connection has been established by welding. In case of doubts a measurement shall be made.

5.3.2.3. Electrolyte spillage

In the period from the impact until 30 minutes after no electrolyte from the REESS shall spill into the passenger compartment and no more than 7 per cent of electrolyte shall spill from the REESS outside the passenger compartment the manufacturer shall demonstrate compliance in accordance with paragraph ANNEX 1.3.5.2. ANNEX 1.

5.3.2.4. REESS retention

REESS located inside the passenger compartment shall remain in the location in which

they are installed and REESS components shall remain inside REESS boundaries.
No part of any REESS that is located outside the passenger compartment for electric safety assessment shall enter the passenger compartment during or after the impact test.

The manufacturer shall demonstrate compliance in accordance with paragraph ANNEX 1.3.5.2.7.

ANEX 1 Test conditions and procedures

1. Compliance tests for fuel system integrity

1.1. Post-crash compressed hydrogen storage system leak test

The crash tests used to evaluate post-crash hydrogen leakage are those already applied in the jurisdictions of each contracting party.

Prior to conducting the crash test, instrumentation is installed in the hydrogen storage system to perform the required pressure and temperature measurements if the standard vehicle does not already have instrumentation with the required accuracy.

The storage system is then purged, if necessary, following manufacturer directions to remove impurities from the container before filling the storage system with compressed hydrogen or helium gas. Since the storage system pressure varies with temperature, the targeted fill pressure is a function of the temperature. The target pressure shall be determined from the following equation:

$$P_{\text{target}} = \text{NWP} \times (273 + T_o) / 288$$

where NWP is the nominal working pressure (MPa), T_o is the ambient temperature to which the storage system is expected to settle, and P_{target} is the targeted fill pressure after the temperature settles.

The container is filled to a minimum of 95 per cent of the targeted fill pressure and allowed to settle (stabilize) prior to conducting the crash test.

The main stop valve and shut-off valves for hydrogen gas, located in the downstream hydrogen gas piping, are kept open immediately prior to the impact.

1.1.1. Post-crash leak test - compressed hydrogen storage system filled with compressed hydrogen

The hydrogen gas pressure, P_0 (MPa), and temperature, T_0 ($^{\circ}\text{C}$), is measured immediately before the impact and then at a time interval, Δt (min), after the impact. The time interval, Δt , starts when the vehicle comes to rest after the impact and continues for at least 60 minutes. The time interval, Δt , is increased if necessary in order to accommodate measurement accuracy for a storage system with a large volume operating up to 70MPa; in that case, Δt can be calculated from the following equation:

$$\Delta t = V_{\text{CHSS}} \times \text{NWP} / 1000 \times ((-0.027 \times \text{NWP} + 4) \times R_s - 0.21) - 1.7 \times R_s$$

where $R_s = P_s / \text{NWP}$, P_s is the pressure range of the pressure sensor (MPa), NWP is the Nominal Working Pressure (MPa), V_{CHSS} is the volume of the compressed hydrogen storage system (L), and Δt is the time interval (min). If the calculated value of Δt is less than 60 minutes, Δt is set to 60 minutes.

The initial mass of hydrogen in the storage system can be calculated as follows:

$$P_0' = P_0 \times 288 / (273 + T_0)$$

$$\rho_0' = -0.0027 \times (P_0'(2 + 0.75 \times P_0' + 0.5789))$$

$$M_0 = \rho_0' \times V_{\text{CHSS}}$$

Correspondingly, the final mass of hydrogen in the storage system, M , at the end of the time interval, Δt , can be calculated as follows:

$$P_f' = P_f \times 288 / (273 + T_f)$$

$$\rho_f' = -0.0027 \times (P_f'(2 + 0.75 \times P_f' + 0.5789))$$

$$M_f = \rho_f' \times V_{\text{CHSS}}$$

where P_f is the measured final pressure (MPa) at the end of the time interval, and T_f is the measured final temperature ($^{\circ}\text{C}$).

The average hydrogen flow rate over the time interval (that shall be less than the criteria in 5.2.2.1.) is therefore

$$V_{\text{H}_2} = (M_f - M_0) / \Delta t \times 22.41 / 2.016 \times (P_{\text{target}} / P_0)$$

where V_{H_2} is the average volumetric flow rate (NL/min) over the time interval and the term $(P_{\text{target}} / P_0)$ is used to compensate for differences between the measured initial pressure, P_0 , and the targeted fill pressure P_{target} .

1.1.2. Post-crash leak test - Compressed hydrogen storage system filled with compressed

helium

The helium gas pressure, P_o (MPa), and temperature T_o (°C), are measured immediately before the impact and then at a predetermined time interval after the impact. The time interval, Δt , starts when the vehicle comes to rest after the impact and continues for at least 60 minutes.

The time interval, Δt , shall be increased if necessary in order to accommodate measurement accuracy for a storage system with a large volume operating up to 70MPa; in that case, Δt can be calculated from the following equation:

$$\Delta t = V_{CHSS} \times NWP / 1000 \times ((-0.028 \times NWP + 5.5) \times R_s - 0.3) - 2.6 \times R_s$$

where $R_s = P_s / NWP$, P_s is the pressure range of the pressure sensor (MPa), NWP is the Nominal Working Pressure (MPa), V_{CHSS} is the volume of the compressed storage system (L), and Δt is the time interval (min). If the value of Δt is less than 60 minutes, Δt is set to 60 minutes.

The initial mass of hydrogen in the storage system is calculated as follows:

$$P_o' = P_o \times 288 / (273 + T_o)$$

$$\rho_o' = -0.0043 \times (P_o')^2 + 1.53 \times P_o' + 1.49$$

$$M_o = \rho_o' \times V_{CHSS}$$

The final mass of hydrogen in the storage system at the end of the time interval, Δt is calculated as follows:

$$P_f' = P_f \times 288 / (273 + T_f)$$

$$\rho_f' = -0.0043 \times (P_f')^2 + 1.53 \times P_f' + 1.49$$

$$M_f = \rho_f' \times V_{CHSS}$$

where P_f is the measured final pressure (MPa) at the end of the time interval, and T_f is the measured final temperature (°C).

The average helium flow rate over the time interval is therefore

$$V_{He} = (M_f - M_o) / \Delta t \times 22.41 / 4.003 \times (P_o / P_{target})$$

where V_{He} is the average volumetric flow rate (NL/min) over the time interval and the term P_o / P_{target} is used to

compensate for differences between the measured initial pressure (P_o) and the targeted fill pressure (P_{target}).

Conversion of the average volumetric flow of helium to the average hydrogen flow is done with the following expression:

$$V_{H_2} = V_{He} / 0.75$$

where V_{H_2} is the corresponding average volumetric flow of hydrogen (that shall be less than the criteria in 5.2.2.1. to pass).

1.2. Post-crash concentration test for enclosed spaces

The measurements are recorded in the crash test that evaluates potential hydrogen (or helium) leakage (1.1. test procedure).

Sensors are selected to measure either the build-up of the hydrogen or helium gas or the reduction in oxygen (due to displacement of air by leaking hydrogen/helium).

Sensors are calibrated to traceable references to ensure an accuracy of ± 5 per cent at the targeted criteria of 4 per cent hydrogen or 3 per cent helium by volume in air, and a full scale measurement capability of at least 25 per cent above the target criteria. The sensor shall be capable of a 90 per cent response to a full scale change in concentration within 10 seconds.

Prior to the crash impact, the sensors are located in the passenger, luggage, and cargo compartments of the vehicle as follows:

- (a) At a distance within 250 mm of the headliner above the driver's seat or near the top centre the passenger compartment;
- (b) At a distance within 250 mm of the floor in front of the rear (or rear most) seat in the passenger compartment;
- (c) At a distance within 100 mm of the top of luggage and cargo compartments within the vehicle that are not directly affected by the particular crash impact to be conducted.

The sensors are securely mounted on the vehicle structure or seats and protected for the planned crash test from debris, air bag exhaust gas and projectiles. The measurements following the crash are recorded by instruments located within the vehicle or by remote transmission.

The vehicle may be located either outdoors in an area protected from the wind and possible solar effects or indoors in a space that is large enough or ventilated to prevent the build-up of hydrogen to more than 10 per cent of the targeted criteria in the passenger,

luggage, and cargo compartments.

Post-crash data collection in enclosed spaces commences when the vehicle comes to a rest.

Data from the sensors are collected at least every 5 seconds and continue for a period of 60 minutes after the test. A first-order lag (time constant) up to a maximum of 5 seconds may be applied to the measurements to provide "smoothing" and filter the effects of spurious data points.

The filtered readings from each sensor shall be below the targeted criteria of 3 ± 1.0 per cent for hydrogen and 2.25 ± 0.75 per cent for helium at all times throughout the 50 minutes post-crash test period.

1.3. Compliance test for single failure conditions

Either test procedure of 1.3.1. or 1.3.2. shall be executed:

1.3.1. Test procedure for vehicle equipped with hydrogen gas leakage detectors

1.3.1.1. Test condition

1.3.1.1.1 Test vehicle: The propulsion system of the test vehicle is started, warmed up to its normal operating temperature, and left operating for the test duration. If the vehicle is not a fuel cell vehicle, it is warmed up and kept idling. If the test vehicle has a system to stop idling automatically, measures are taken so as to prevent the engine from stopping.

1.3.1.1.2. Test gas: Two mixtures of air and hydrogen gas: 2 ± 1.0 per cent concentration (or less) of hydrogen in the air to verify function of the warning, and 3 ± 1.0 per cent concentration (or less) of hydrogen in the air to verify function of the shut-down. The proper concentrations are selected based on the recommendation (or the detector specification) by the manufacturer.

1.3.1.2. Test method

1.3.1.2.1. Preparation for the test: The test is conducted without any influence of wind.

- (a) A test gas induction hose is attached to the hydrogen gas leakage detector;
- (b) The hydrogen leak detector is enclosed with a cover to make gas stay around hydrogen leak detector.

1.3.1.2.2. Execution of the test

- (a) Test gas is blown to the hydrogen gas leakage detector,
- (b) Proper function of the warning system is confirmed when tested with the gas to verify function of the warning.
- (c) The main shut-off valve is confirmed to be closed when tested with the gas to verify function of the shut-down. For example, the monitoring of the electric power to the shut-off valve or of the sound of the shut-off valve activation may be used to confirm the operation of the main shut-off valve of the hydrogen supply.

1.3.2. Test procedure for integrity of enclosed spaces and detection systems.

1.3.2.1. Preparation: 1.3.2.1.1. The test is conducted without any influence of wind.

1.3.2.1.2. Special attention is paid to the test environment as during the test flammable mixtures of hydrogen and air may occur.

1.3.2.1.3. Prior to the test the vehicle is prepared to allow remotely controllable hydrogen releases from the hydrogen system. The number, location and flow capacity of the release points downstream of the main hydrogen shutoff valve are defined by the vehicle manufacturer taking worst case leakage scenarios into account. As a minimum, the total flow of all remotely controlled releases shall be adequate to trigger demonstration of the automatic "warning" and hydrogen shut-off functions.

1.3.2.1.4. For the purpose of the test, a hydrogen concentration detector is installed where hydrogen gas may accumulate most in the passenger compartment (e.g. near the headliner) when testing for compliance with 5.2.1.4.2. and hydrogen concentration detectors are installed in enclosed or semi enclosed volumes on the vehicle where hydrogen can accumulate from the simulated hydrogen releases when testing for compliance with 5.2.1.4.3. (see 1.3.2.1.3.).

1.3.2.2. Procedure:

1.3.2.2.1. Vehicle doors, windows and other covers are closed.

1.3.2.2.2. The propulsion system is started, allowed to warm up to its normal operating temperature and left operating at idle for the test duration

1.3.2.2.3. A leak is simulated using the remote controllable function.

1.3.2.2.4. The hydrogen concentration is measured continuously until the concentration does not rise for 3 minutes. When testing for compliance with 5.2.1.4.3., the simulated leak

is then increased using the remote controllable function until the main hydrogen shutoff valve is closed and the tell-tale warning signal is activated. The monitoring of the electric power to the shut-off valve or of the sound of the shut-off valve activation may be used to confirm the operation of the main shut-off valve of the hydrogen supply.

1.3.2.2.5. When testing for compliance with 5.2.1.4.2., the test is successfully completed if the hydrogen concentration in the passenger compartment does not exceed 1.0 per cent. When testing for compliance with 5.2.1.4.3., the test is successfully completed if the tell-tale warning and shut-off function are executed at (or below) the levels specified in 5.2.1.4.3.; otherwise, the test is failed and the system is not qualified for vehicle service.

1.4. Compliance test for the vehicle exhaust system

1.4.1. The power system of the test vehicle (e.g. fuel cell stack or engine) is warmed up to its normal operating temperature.

1.4.2. The measuring device is warmed up before use to its normal operating temperature,

1.4.3. The measuring section of the measuring device is placed on the centre line of the exhaust gas flow within 100 mm from the exhaust gas outlet external to the vehicle.

1.4.4. The exhaust hydrogen concentration is continuously measured during the following steps:

- (a) The power system is shut down;
- (b) Upon completion of the shut-down process, the power system is immediately started;
- (c) After a lapse of one minute, the power system is turned off and measurement continues until the power system shut-down procedure is completed.

1.4.5. The measurement device shall have a measurement response time of less than 300 milliseconds.

1.5. Compliance test for fuel line leakage

1.5.1. The power system of the test vehicle (e.g. fuel cell stack or engine) is warmed up and operating at its normal operating temperature with the operating pressure applied to fuel lines.

1.5.2. Hydrogen leakage is evaluated at accessible sections of the fuel lines from the high-

pressure section to the fuel cell stack (or the engine), using a gas detector or leak detecting liquid, such as soap solution.

1.5.3. Hydrogen leak detection is performed primarily at joints

1.5.4. When a gas leak detector is used detection is performed by operating the leak detector for at least 10 seconds at locations as close to fuel lines as possible.

1.5.5. When a leak detecting liquid is used, hydrogen gas leak detection is performed immediately after applying the liquid. In addition, visual checks are performed a few minutes after the application of liquid in order to check for bubbles caused by trace leaks.

1. Installation verification

The system is visually inspected for compliance.

2. Test procedures for compressed hydrogen storage

2.1. Test procedures for qualification requirements of compressed hydrogen storage are organized as follows:

Section 2.2 is the test procedures for baseline performance metrics (requirement of 5.1.1.)

Paragraph 2.3 is the test procedures for performance durability (requirement of 5.1.2.)

Paragraph 2.4 is the test procedures for expected on-road performance (requirement of 5.1.3.)

Paragraph 2.5 is the test procedures for service terminating performance in Fire (requirement of 5.1.4.)

Paragraph 2.6 is the test procedures for performance durability of primary closures (requirement of 5.1.5.)

2.2 Test procedures for baseline performance metrics (requirement of 5.1.1.)

2.2.1. Burst test (hydraulic)

The burst test is conducted at 20(±5)°C using a non-corrosive fluid. The rate of pressurization is less than or equal to 1.4 MPa/s for pressures higher than 150 per cent of the nominal working pressure. If the rate exceeds 0.35 MPa/s at pressures higher than 150 per cent NWP, then either the container is placed in series between the pressure source and the

pressure measurement device, or the time at the pressure above a target burst pressure exceeds 5 seconds. The burst pressure of the container shall be recorded

2.2.2. Pressure cycling test (hydraulic)

The test is performed in accordance with the following procedure:

- (a) The container is filled with a non-corrosive fluid;
- (b) The container and fluid are stabilized at the specified temperature and relative humidity at the start of testing the environment, fuelling fluid and container skin are maintained at the specified temperature for the duration of the testing. The container temperature may vary from the environmental temperature during testing;
- (c) The container is pressure cycled between 2 (± 1) MPa and the target pressure at a rate not exceeding 10 cycles per minute for the specified number of cycles;
- (d) The temperature of the hydraulic fluid within the container is maintained and monitored at the specified temperature.

2.3 Test procedures for performance durability (requirement of 5.1.2.)

2.3.1. Proof pressure test

The system is pressurized smoothly and continually with a non-corrosive hydraulic fluid until the target test pressure level is reached and then held for the specified time.

2.3.2. Drop (impact) test (unpressurized)

The storage container is drop tested at ambient temperature without internal pressurization or attached valves. The surface onto which the containers are dropped shall be a smooth, horizontal concrete pad or other flooring type with equivalent hardness.

- (a) The orientation of the container being dropped (per requirement of 5.1.2.2.) is determined as follows: One or more additional container(s) shall be dropped in each of the orientations described below. The drop orientations may be executed with a single container or as many as four containers may be used to accomplish the four drop orientations.
 - (i) Dropped once from a horizontal position with the bottom 1.8 m above the surface onto which it is dropped;
 - (ii) Dropped once onto the end of the container from a vertical position with the ported end upward with a potential energy of not less than 488 J, with the height of the lower

- end no greater than 1.8 m;
- (iii) Dropped once onto the end of the container from a vertical position with the ported end downward with a potential energy of not less than 488 J, with the height of the lower end no greater than 1.8 m. If the container is symmetrical (identical ported ends), this drop orientation is not required;
 - (iv) Dropped once at a 45° angle from the vertical orientation with a ported end downward with its centre of gravity 1.8 m above the ground. However, if the bottom is closer to the ground than 0.6 m, the drop angle shall be changed to maintain a minimum height of 0.6 m and a centre of gravity of 1.8 m above the ground.

The four drop orientations are illustrated below.

Figure 5

Drop orientations

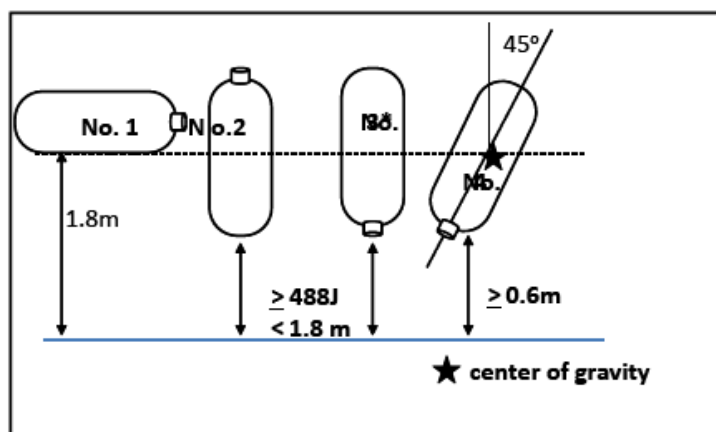

No attempt shall be made to prevent the bouncing of containers, but the containers may be prevented from falling over during the vertical drop test described in b) above.

If more than one container is used to execute all three drop specifications, then those containers shall undergo pressure cycling according to 2.2.2. until either leakage or 22,000 cycles without leakage have occurred. Leakage shall not occur within number of Cycles (5,500, 7,500 or 11,000).

The orientation of the container being dropped per requirement 5.1.2.2. shall be identified as follows:

- (a) If a single container was subjected to all four drop orientations, then the container being dropped per requirement of 5.1.2.2. shall be dropped in all four orientations;

- (b) If more than one container is used to execute the four drop orientations, and if all containers reach 22,000 cycles without leakage, then the orientation of the container being dropped per requirement 5.1.2.2. is the 45° orientation (iv), and that container shall then undergo further testing as specified in paragraph 5.1.2.;
- (c) If more than one container is used to execute the four drop orientations and if any container does not reach 22,000 cycles without leakage, then the new container shall be subjected to the drop orientation(s) that resulted in the lowest number of cycles to leakage and then will undergo further testing as specified in paragraph 5.1.2.

2.3.3. Surface damage test (unpressurized)

The test proceeds in the following sequence:

- (a) Surface flaw generation: Two longitudinal saw cuts are made on the bottom outer surface of the unpressurized horizontal storage container along the cylindrical zone close to but not in the shoulder area. The first cut is at least 1.25 mm deep and 25 mm long toward the valve end of the container. The second cut is at least 0.75 mm deep and 200 mm long toward the end of the container opposite the valve;
- (b) Pendulum impacts: The upper section of the horizontal storage container is divided into five distinct (not overlapping) areas 100 mm in diameter each (see Figure 6). After 12 hours preconditioning at - 40 °C in an environmental chamber, the centre of each of the five areas sustains the impact of a pendulum having a pyramid with equilateral faces and square base, the summit and edges being rounded to a radius of 3 mm. The centre of impact of the pendulum coincides with the centre of gravity of the pyramid. The energy of the pendulum at the moment of impact with each of the five marked areas on the container is 30). The container is secured in place during pendulum impacts and not under pressure.

Figure 6

Side view of tank

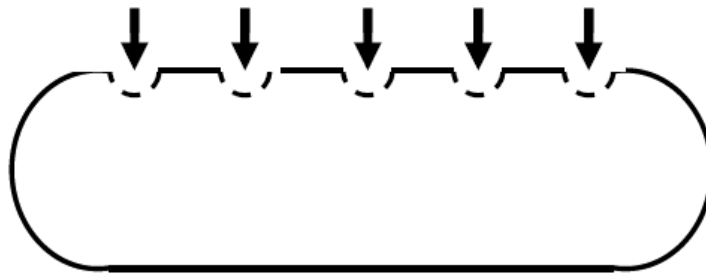

"Side" View of Tank

2.3.4. Chemical exposure and ambient temperature pressure cycling test

Each of the 5 areas of the unpressurized container preconditioned by pendulum impact (paragraph 4.2.5.2.) is exposed to one of five solutions:

- (a) 19 per cent (by volume) sulphuric acid in water (battery acid);
- (b) 25 per cent (by weight) sodium hydroxide in water;
- (c) 5 per cent (by volume) methanol in gasoline (fluids in fuelling stations);
- (d) 28 per cent (by weight) ammonium nitrate in water (urea solution), and
- (e) 50 per cent (by volume) methyl alcohol in water (windshield washer fluid).

The test container is oriented with the fluid exposure areas on top. A pad of glass wool approximately 0.5 mm thick and 100 mm in diameter is placed on each of the five preconditioned areas. A sufficient amount of the test fluid is applied to the glass wool sufficient to ensure that the pad is wetted across its surface and through its thickness for the duration of the test.

The exposure of the container with the glass wool is maintained for 48 hrs with the container held at 125 per cent NWP (applied hydraulically) and 20 (±5) °C before the container is subjected to further testing.

Pressure cycling is performed to the specified target pressures according to paragraph 2.2.2. at 20 (±5) °C for the specified numbers of cycles. The glass wool pads are removed and the container surface is rinsed with water the final 10 cycles to specified final target pressure are conducted.

2.3.5. Static pressure test (hydraulic)

The storage system is pressurized to the target pressure in a temperature-controlled chamber.

The temperature of the chamber and the non-corrosive fuelling fluid is held at the target temperature within $\pm 5^{\circ}\text{C}$ for the specified duration.

2.4 Test procedures for expected on-road performance (5.1.3.)

(Pneumatic test procedures are provided; hydraulic test elements are described in 3.2.)

2.4.1. Gas pressure cycling test (pneumatic)

At the onset of testing, the storage system is stabilized at the specified temperature, relative humidity and fuel level for at least 24 hrs. The specified temperature and relative humidity is maintained within the test environment throughout the remainder of the test. (When required in the test specification, the system temperature is stabilized at the external environmental temperature between pressure cycles.) The storage system is pressure cycled between less than $2(+0/-1)$ MPa and the specified maximum pressure (1MPa). If system controls that are active in vehicle service prevent the pressure from dropping below a specified pressure, the test cycles shall not go below that specified pressure. The fill rate is controlled to a constant 3-minute pressure ramp rate, but with the fuel flow not to exceed 60 g/s; the temperature of the hydrogen fuel dispensed to the container is controlled to the specified temperature. However, the pressure ramp rate should be decreased if the gas temperature in the container exceeds 85°C . The defuelling rate is controlled to greater than or equal to the intended vehicle's maximum fuel-demand rate. The specified number of pressure cycles is conducted. If devices and/or controls are used in the intended vehicle application to prevent an extreme internal temperature, the test may be conducted with these devices and/or controls (or equivalent measures).

2.4.2. Gas permeation test (pneumatic)

A storage system is fully filled with hydrogen gas at 115 per cent NWP (full fill density equivalent to 100 per cent NWP at $+15^{\circ}\text{C}$ is 113 per cent NWP at $+55^{\circ}\text{C}$) and held at $\geq +55^{\circ}\text{C}$ in a sealed container until steady-state permeation or 30 hours, whichever is longer. The total steady-state discharge rate due to leakage and permeation from the storage system is measured.

2.4.3. Localized gas leak test (pneumatic)

A bubble test may be used to fulfill this requirement. The following procedure is used when

conducting the bubble test:

- (a) The exhaust of the shutoff valve (and other internal connections to hydrogen systems) shall be capped for this test (as the test is focused at external leakage). At the discretion of the tester, the test article may be immersed in the leak-test fluid or leak-test fluid applied to the test article when resting in open air. Bubbles can vary greatly in size, depending on conditions. The tester estimates the gas leakage based on the size and rate of bubble formation.
- (b) *Note.* For a localized rate of 0.005 mg/sec (3.6 NmL/min), the resultant allowable rate of bubble generation is about 2,030 bubbles per minute for a typical bubble size of 1.5 mm in diameter. Even if much larger bubbles are formed, the leak should be readily detectable. For an unusually large bubble size of 6 mm in diameter, the allowable bubble rate would be approximately 32 bubbles per minute.

2.5 Test procedures for service terminating performance in fire (5.1.4.)

2.5.1. Fire test

The hydrogen container assembly consists of the compressed hydrogen storage system with additional relevant features, including the venting system (such as the vent line and vent line covering) and any shielding affixed directly to the container (such as thermal wraps of the container(s) and/or coverings/barriers over the TPRD(s). Either one of the following two methods are used to identify the position of the system over the initial (localized) fire source:

2.5.1.1. Method 1: Qualification for a generic (non-Specific) vehicle installation

If a vehicle installation configuration is not specified and the qualification of the system is not limited to a specific vehicle installation configuration) then the localized fire exposure area is the area on the test article farthest from the TPRD(s). The test article as specified above, only includes thermal shielding or other mitigation devices affixed directly to the container that are used in all vehicle applications. Venting system(s) (such as the vent line and vent line covering) and/or coverings/barriers over the TPRD(s) are included in the container assembly if they are anticipated for use in any application. If a system is tested without representative components, retesting of that system is required if a vehicle application specifies the use of these type of

components.

2.5.1.2. Method 2: Qualification for a specific vehicle installation

If a specific vehicle installation configuration is specified and the qualification of the system is limited to that specific vehicle installation configuration, then the test setup may also include other vehicle components in addition to the hydrogen storage system. These vehicle components (such as shielding or barriers, which are permanently attached to the vehicle's structure by means of welding or bolts and not affixed to the storage system) shall be included in the test setup in the vehicle-installed configuration relative to the hydrogen storage system. This localized fire test is conducted on the worst case localized fire exposure areas based on the four fire orientations: fires originating from the direction of the passenger compartment, cargo/luggage compartment, wheel wells or ground-pooled gasoline. The container may be subjected to engulfing fire without any shielding components, as described in paragraph 2.5.2.

The following test requirements apply whether Method or 2 (above) is used:

- (a) The container assembly is filled with compressed hydrogen gas at 100 per cent of NWP. The container assembly is positioned horizontally approximately 100 mm above the fire source. (Note: as stated in 5.1.4., contracting parties under the 1998 Agreement may choose to use compressed air as an alternative test gas for certification of the container for use in their countries or regions.); Localized portion of the fire test.
- (b) The localized fire exposure area is located on the test article furthest from the TPRD(s). If Method 2 is selected and more vulnerable areas are identified for a specific vehicle installation configuration, the more vulnerable area that is furthest from the TPRD(s) is positioned directly over the initial fire source;
- (c) The fire source consists of LPG burners configured to produce a uniform minimum temperature on the test article measured with a minimum 5 thermocouples covering the length of the test article up to 1.65 m maximum (at least 2 thermocouples within the localized fire area, and at least 3 thermocouples equally spaced and no more than 0.5 m apart in the remaining area) located 25 mm 10mm from the outside surface of the test article along its longitudinal axis. At the option of the manufacturer or testing

facility, additional thermocouples may be located at TPRD sensing points or any other locations for optional diagnostic purposes;

- (d) Wind shields are applied to ensure uniform heating
- (e) The fire source initiates within a 250 mm +50 mm longitudinal expanse positioned under the localized exposure area of the test article. The width of the fire source encompasses the entire diameter (width) of the storage system. If Method 2 is selected, the length and width shall be reduced, if necessary, w account for vehicle-specific features;
- (f) As shown in Figure 7 the temperature of the thermocouples in the localized fire area has increased continuously to at least 300 °C within 1 minute of ignition, to at least 600 °C within 3 minutes of ignition, to at least 600 °C within 3 minutes of ignition, and a temperature of at least 600 °C is maintained for the next 7 minutes. The temperature in the localized fire area shall not exceed 900°C during this period. Compliance to the thermal requirements begins 1 minute after entering the period with minimum and maximum limits and is based on a 1-minute rolling average of each thermocouple in the region of interest. (Note: The temperature outside the region of the initial fire source is not specified during these initial 10 minutes from the time of ignition.).

Figure 7

Temperature profile of fire test

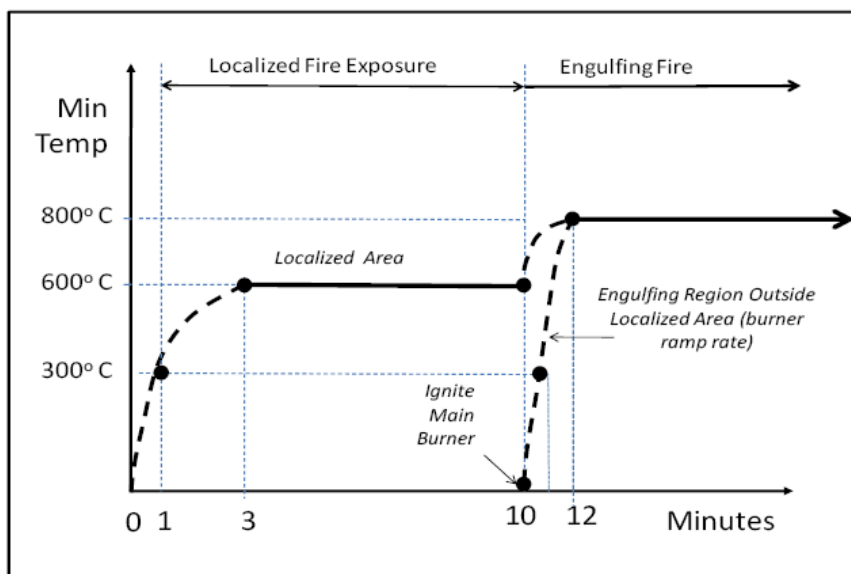

Engulfing portion of the fire test

Within the next 2-minute interval, the temperature along the entire surface of the test article shall be increased to at least 800 °C and the fire source is extended to produce a uniform temperature along the entire length up to 1.65 meters and the entire width of the test article engulfing fire). The minimum temperature is held at 800°C, and the maximum temperature shall not exceed 1100 °C. Compliance to thermal requirements begins 1 minute after entering the period with constant minimum and maximum limits and is based on a 1-minute rolling average of each thermocouple. The test article is held at temperature (engulfing fire condition) until the system vents through the TPRD and the pressure falls to less than 1 MPa. The venting shall be continuous (without interruption), and the storage system shall not rupture. An additional release through leakage (not including release through the TPRD) that results in a flame with length greater than 0.5 m beyond the perimeter of the applied flame shall not occur.

Table 2
Summary of fire test protocol

	<i>Localized fire region</i>	<i>Time period</i>	<i>Engulfing fire region (Outside the localized fire region)</i>
Action	Ignite Burners	0-1 minute	No Burner Operation
Minimum temperature	Not specified		Not specified
Maximum temperature	Less than 900°C		Not specified
Action	Increase temperature and stabilize fire for start of localized fire exposure	1-3 minutes	No Burner Operation
Minimum temperature	Greater than 300°C		Not specified
Maximum temperature	Less than 900°C		Not specified
Action	Localized fire exposure continues	3-10 minutes	No Burner Operation
Minimum temperature	1-minute rolling average greater than 600°C		Not specified
Maximum temperature	1-minute rolling average less than 900°C		Not specified
Action	Increase temperature	10-11 minutes	Main Burner Ignited at 10 minutes
Minimum temperature	1-minute rolling average greater than 600°C		Not specified
Maximum temperature	1-minute rolling average less than 1,100°C		Less than 1,100°C

	<i>Localized fire region</i>	<i>Time period</i>	<i>Engulfing fire region (Outside the localized fire region)</i>
Action	Increase temperature and stabilize fire for start of engulfing fire exposure	11-12 minutes	Increase temperature and stabilize fire for start of engulfing fire exposure
Minimum temperature	1-minute rolling average greater than 600°C		Greater than 300°C
Maximum temperature	1 minute rolling average less than 1,100°C		Less than 1,100°C
Action	Engulfing fire exposure continues	12 minutes - end of test	Engulfing fire – exposure continues
Minimum temperature	1-minute rolling average greater than 800°C		1-minute rolling average greater than 800°C
Maximum temperature	1-minute rolling average less than 1,100°C		1 minute rolling average less than 1,100°C

Documenting results of the fire test

The arrangement of the fire is recorded in sufficient detail to ensure the rate of heat input to the test article is reproducible. The results include the elapsed time from ignition of the fire to the start of venting through the TPRD(s), and the maximum pressure and time of evacuation until a pressure of less than 1 MPa is reached. Thermocouple temperatures and container pressure are recorded at intervals of every 10 sec or less during the test. Any failure to maintain specified minimum temperature requirements based on the 1-minute rolling averages invalidates the test result. Any

failure to maintain

specified maximum temperature requirements based on the 1-minute rolling averages invalidates the test result only if the test article failed during the test.

2.5.2. Engulfing fire test:

The test unit is the compressed hydrogen storage system. The storage system is filled with compressed hydrogen gas at 100 per cent NWP. The container is positioned horizontally with the container bottom approximately 100 mm above the fire source. Metallic shielding is used to prevent direct flame impingement on container valves, fittings, and/or pressure relief devices. The metallic shielding is not in direct contact with the specified fire protection system (pressure relief devices or container valve). A uniform fire source of 1.65 m length provides direct flame impingement on the container surface across its entire diameter. The test shall continue until the container fully vents (until the container pressure falls below 0.7 MPa (100 psi)). Any failure or inconsistency of the fire source during a test shall invalidate the result.

Flame temperatures shall be monitored by at least three thermocouples suspended in the flame approximately 25 mm below the bottom of the container. Thermocouples may be attached to steel cubes up to 25 mm on a side. Thermocouple temperature and the container pressure shall be recorded every 30 seconds during the test.

Within five minutes after the fire is ignited, an average flame temperature of not less than 590°C (as determined by the average of the two thermocouples recording the highest temperatures over a 60 second interval) is attained and maintained for the duration of the test.

If the container is less than 1.65 m in length, the centre of the container shall be positioned over the centre of the fire source. If the container is greater than 1.65 m in length, then if the container is fitted with a pressure relief device at one end, the fire source shall commence at the opposite end of the container. If the container is greater than 1.65 m in length and is fitted with pressure relief devices at both ends, or at more than one location along the length of the container, the centre of the fire source shall be centred midway between the pressure relief devices that are separated by the greatest horizontal distance.

The container shall vent through a pressure relief device without bursting.

2. Test Procedures for performance durability of primary closures (5.1.5. requirement).

1.1. Compressed hydrogen storage TPRD qualification performance tests

Testing is performed with hydrogen gas having gas quality compliant with ISO 14687-2/SAE J2719. All tests are performed at ambient temperature of 20 (± 5) °C unless otherwise specified. The TPRD qualification performance tests are specified as follows:

2.1.1. Pressure cycling test.

Five TPRD units undergo 11,000 internal pressure cycles with hydrogen gas having gas quality compliant with ISO 14687-2/SAE J2719. The first five pressure cycles are between 2 (± 1) MPa and 150 per cent NWP (± 1 MPa); the remaining cycles are between 2 (± 1) MPa and 125 per cent NWP (± 1 MPa). The first 1500 pressure cycles are conducted at a TPRD temperature of 55 °C or higher. The remaining cycles are conducted at a TPRD temperature of 55 (± 5)°C. The maximum pressure cycling rate is ten cycles per minute. Following this test, the pressure relief device shall comply the requirements of the Leak Test (2. 1.8.), Flow Rate Test (2. 1.10.) and the Bench Top Activation Test (2. 1.9.).

2.1.2. Accelerated life test.

Eight TPRD units undergo testing three at the manufacturer's specified activation temperature, T_{act} , and five at an accelerated life temperature, $T_{life}=9.1 \times T_{act}^{0.503}$. The TPRD is placed in an oven or liquid bath with the temperature held constant ($\pm 1^\circ\text{C}$). The hydrogen gas pressure on the TPRD inlet is 125 per cent NWP (± 1 MPa). The pressure supply may be located outside the controlled temperature oven or bath. Each device is pressured individually or through a manifold system. If a manifold system is used, each pressure connection includes a check valve to prevent pressure depletion of the system when one specimen fails. The three TPRDs tested at T_{act} shall activate in less than ten hours. The five TPRDs tested at T_{life} shall not activate in less than 500 hours.

2.1.3. Temperature cycling test

- (a) An unpressurized TPRD is placed in a liquid bath maintained at -40°C or lower at least

two hours. The TPRD is transferred to a liquid bath maintained at 85 °C or higher within five minutes, and maintained at that temperature at least two hours. The TPRD is transferred to a liquid bath maintained at -40 °C or lower within five minutes;

- (b) Step is repeated until 15 thermal cycles have been achieved;
- (c) With the TPRD conditioned for a minimum of two hours in the -40°C or lower liquid bath, the internal pressure of the TPRD is cycled with hydrogen gas between 2MPa (+1/-0MPa) and 80 per cent NWP (+2/-0MPa) for 100 cycles while the liquid bath is maintained at - 40 °C or lower;
- (d) Following the thermal and pressure cycling the pressure relief device shall comply with the requirements of the Leak Test (2. 1.8.), except that the Leak Test shall be conducted at - 40 °C ($\pm 5/-0^{\circ}\text{C}$). After the Leak Test, the TPRD shall comply with the requirements of the Bench Top Activation Test (2. 1.9.) and then the Flow Rate Test (2.1.10.).

2.1.4. Salt corrosion resistance test

Two TPRD units are tested. Any non-permanent outlet caps are removed. Each TPRD unit is installed in a test fixture in accordance with the manufacturer's recommended procedure so that external exposure is consistent with realistic installation. Each unit is exposed for 500 hours to a salt spray (fog) test as specified in ASTM B117 (Standard Practice for Operating Salt Spray (Fog) Apparatus) except that in the test of one unit, the pH of the salt solution shall be adjusted to 4.0 ± 0.2 by the addition of sulphuric acid and nitric acid in a 2:1 ratio, and in the test of the other unit, the pH of the salt solution shall be adjusted to 10.0 ± 0.2 by the addition of sodium hydroxide. The temperature within the fog chamber is maintained at 30-35°C).

Following these tests, each pressure relief device shall comply with the requirements of the leak test (2. 1.8.), Flow Rate Test (2.1.10.) and bench top activation test (2. 1.9.).

2.1.5. Vehicle environment test

Resistance to degradation by external exposure to automotive fluids is determined by the following test:

- (a) The inlet and outlet connections of the TPRD are connected or capped in accordance

with the manufacturers installation instructions. The external surfaces of the TPRD are exposed for 24 hours at 20 (± 5) °C to each of the following fluids:

- (i) Sulphuric acid - 19 per cent solution by volume in water,
 - (ii) Sodium hydroxide-25 per cent solution by weight in water,
 - (iii) Ammonium nitrate - 28 per cent by weight in water; and
 - (iv) Windshield washer fluid (50 per cent by volume methyl alcohol and water).
- (a) The fluids are replenished as needed to ensure complete exposure for the duration of the test. A distinct test is performed with each of the fluids. One component may be used for exposure to all of the fluids in sequence. After exposure to each fluid, the component is wiped off and rinsed with water;
- (b) The component shall not show signs of physical degradation that could impair the function of the component, specifically: cracking, softening, or swelling. Cosmetic changes such as pitting or staining are not failures. At the conclusion of all exposures, the unit(s) shall comply with the requirements of the Leak Test (2.1.8.), Flow Rate Test (2.1.10.) and Bench Top Activation test (2.1.9.).

2.1. Stress corrosion cracking test.

For TPRDs containing components made of a copper-based alloy (e.g. brass), one TPRD unit is tested. All copper alloy components exposed to the atmosphere shall be degreased and then continuously exposed for ten days to a moist ammonia-air mixture maintained in a glass chamber having a glass cover.

Aqueous ammonia having a specific gravity of 0.94 is maintained at the bottom of the glass chamber below the sample at a concentration of at least 20 ml per litre of chamber volume. The sample is positioned 35 (± 5) mm above the aqueous ammonia solution and supported in an inert tray. The moist ammonia-air mixture is maintained at atmospheric pressure at 35 (± 5) °C. Copper-based alloy components shall not exhibit cracking or delaminating due to this test.

2.1.7. Drop and vibration test

- (a) Six TPRD units are dropped from a height of 2 m at ambient temperature ($20 \pm 5^\circ\text{C}$) onto a smooth concrete surface. Each sample is allowed to bounce on the concrete surface after the initial impact. One unit is dropped in six orientations (opposing

directions of 3 orthogonal axes: vertical, lateral and longitudinal). If each of the six dropped samples does not show visible exterior damage that indicates that the part is unsuitable for use, it shall proceed to step (b);

- (b) Each of the six TPRD units dropped in step (a) and one additional unit not subjected to a drop are mounted in a test fixture in accordance with manufacturer's installation instructions and vibrated 30 minutes along each of the three orthogonal axes (vertical, lateral and longitudinal) at the most severe resonant frequency for each axis. The most severe resonant frequencies are determined using an acceleration of 1.5 g and sweeping through a sinusoidal frequency range of 10 to 500 Hz within 10 minutes. The resonance frequency is identified by a pronounced increase in vibration amplitude. If the resonance frequency is not found in this range, the test shall be conducted at 40 Hz. Following this test, each sample shall not show visible exterior damage that indicates that the part is unsuitable for use. It shall subsequently comply with the requirements of the Leak Test (2.1.8.), Flow Rate Test (2.1.10.) and Bench Top Activation Test (2.1.9.).

2. 1.8. Leak test

ATPRD that has not undergone previous testing is tested at ambient, high and low temperatures without being subjected to other design qualification tests. The unit is held for one hour at each temperature and test pressure before testing. The three temperature test conditions are:

- (a) Ambient temperature: condition the unit at 20 (± 5) °C; test at 5 per cent NWP (+0/-2MPa) and 150 per cent NWP (+2/-0MPa);
- (b) High temperature: condition the unit at 85 °C or higher; test at 5 per cent NWP (+0/-2MPa) and 150 per cent NWP (+2/-0MPa);
- (c) Low temperature: condition the unit at -40°C or lower; test at 5 per cent NWP (+0/-2MPa) and 100 per cent NWP (+2/-0MPa).

Additional units undergo leak testing as specified in other tests in 2. 1. with uninterrupted exposure at the temperature specified in those tests.

At all specified test temperatures, the unit is conditioned for one minute by immersion in a temperature controlled fluid (or equivalent method). If no bubbles are observed for

the specified time period, the sample passes the test. If bubbles are detected the leak rate is measured by an appropriate method. The total hydrogen leak rate shall be less than 10 NmL/hr.

2.1.9. Bench top activation test

Two new TPRD units are tested without being subjected to other design qualification tests in order to establish a baseline time for activation. Additional pre-tested units (pre-tested according to paras. 2. 1.1., 2. 1.3., 2. 1.4., 2. 1.5. or 2. 1.7.) undergo bench top activation testing as specified in other tests in 2.1.

- (a) The test setup consists of either an oven or chimney which is capable of controlling air temperature and flow to achieve $600 (\pm 10)^{\circ}\text{C}$ in the air surrounding the TPRD. The TPRD unit is not exposed directly to flame. The TPRD unit is mounted in a fixture according to the manufacturer's installation instructions; the test configuration is to be documented;
- (b) A thermocouple is placed in the oven or chimney to monitor the temperature. The temperature remains within the acceptable range for two minutes prior to running the test;
- (c) The pressurized TPRD unit is inserted into the oven or chimney, and the time for the device to activate is recorded. Prior to insertion into the oven or chimney, one new (not pre-tested) TPRD unit is pressurized to no more than 25 per cent NWP (the pre-tested); TPRD units are pressurized to no more than 25 per cent NWP; and one new (not pre-tested) TPRD unit is pressurized to 100 per cent NWP;
- (d) TPRD units previously subjected to other tests in 2. 1. shall activate within a period no more than two minutes longer than the baseline activation time of the new TPRD unit that was pressurized to up to 25 per cent NWP;
- (e) The difference in the activation time of the two TPRD units that had not undergone previous testing shall be no more than 2 minutes.

2. 1.10. Flow rate test

- (a) Eight TPRD units are tested for flow capacity. The eight units consist of three new TPRD units and one TRPD unit from each of the following previous tests: paras. 2. 1.1., 2. 1.3., 2. 1.4., 2. 1.5. and 2. 1.7.;

- (b) Each TPRD unit is activated according to 2. 1.9. After activation and without cleaning, removal of parts, or reconditioning, each TPRD unit is subjected to flow test using hydrogen, air or an inert gas; Flow rate testing is conducted with a gas inlet pressure of 2 (± 0.5) MPa. The outlet is at ambient pressure. The inlet temperature and pressure are recorded;
- (c) Flow rate is measured with accuracy within ± 2 per cent. The lowest measured value of the eight pressure relief devices shall not be less than 90 per cent of the highest slow value.

2.2. Compressed hydrogen storage qualification performance tests for check valve and shut-off valve Testing shall be performed with hydrogen gas having gas quality compliant with ISO 14687-2/SAE 12719. All tests are performed at ambient temperature 20 (± 5)°C unless otherwise specified. The check valve and shut-off valve qualification performance tests are specified as follows:

2.2.1. Hydrostatic strength test

The outlet opening in components is plugged and valve stats or internal blocks are made to assume the open position. One unit is tested without being subjected to other design qualification tests in order to establish a baseline burst pressure, other units are tested as specified in subsequent tests of 2.2.

- (a) A hydrostatic pressure of 250 per cent NWP ($+2/-0$ MPa) is applied to the inlet of the component for three minutes. The component is examined to ensure that rupture has not occurred;
- (b) The hydrostatic pressure is then increased at a rate of less than or equal to 1.4 MPa/sec until component failure. The hydrostatic pressure at failure is recorded. The failure pressure of previously tested units shall be no less than 80 per cent of the failure pressure of the baseline, unless the hydrostatic pressure exceeds 400 per cent NWP.

2.2.2. Leak test

One unit that has not undergone previous testing is tested at ambient, high and low temperatures without being subjected to other design qualification tests. The three temperature test conditions are:

- (a) Ambient temperature: condition the unit at 20 (± 5) °C; test at 5 per cent NWP ($+0/-2$

- MPa) and 150 per cent NWP (+2/-0 MPa);
- (b) High temperature: condition the unit at 85 °C or higher; test at 5 per cent NWP (+0/-2 MPa) and 150 per cent NWP (+2/-0 MPa);
 - (c) Low temperature: condition the unit at -40 °C or lower; test at 5 per cent NWP (+0/-2 MPa) and 100 per cent NWP (+2/-0 MPa).

Additional units undergo leak testing as specified in other tests in 2.2. with uninterrupted exposure at the temperatures specified in those tests. The outlet opening is plugged with the appropriate mating connection and pressurized hydrogen is applied to the inlet. At all specified test temperatures, the unit is conditioned for one minute by immersion in a temperature controlled fluid (or equivalent method). If no bubbles are observed for the specified time period, the sample passes the test. If bubbles are detected, the leak rate is measured by an appropriate method. The leak rate shall not exceed 10 Nml/hr of hydrogen gas.

2.2.3. Extreme temperature pressure cycling test

- (a) The total number of operational cycles is 11,000 for the check valve and 50,000 for the shut-off valve. The valve units are installed in a test fixture corresponding to the manufacturer's specifications for installation. The operation of the unit is continuously repeated using hydrogen gas at all specified pressures.

An operational cycle shall be defined as follows:

- (i) A check valve is connected to a test fixture and 100 per cent NWP (+2/-0 MPa) is applied in six step pulses to the check valve inlet with the outlet closed. The pressure is then vented from the check valve inlet. The pressure is lowered on the check valve outlet side to less than 60 per cent NWP prior to the next cycle;
 - (ii) A shut-off valve is connected to a test fixture and pressure is applied continuously to the both the inlet and outlet sides. An operational cycle consists of one full operation and reset.
- (b) Testing is performed on a unit stabilized at the following temperatures:
 - (i) Ambient temperature cycling. The unit undergoes operational (open/closed) cycles at 125 per cent NWP (+2/-0 MPa) through 90 per cent of the total cycles with the part stabilized at 20 (±5) °C. At the completion of the ambient temperature

operational cycles, the unit shall comply with the ambient temperature leak test specified in 2.2.2.;

- (ii) High temperature cycling. The unit then undergoes operational cycles at 125 per cent NWP (+2/-0 MPa) through 5 per cent of the total operational cycles with the part stabilized at 85°C or higher. At the completion of the 85°C cycles, the unit shall comply with the high temperature (85 °C) leak test specified in 2.2.2.
- (iii) Low temperature cycling. The unit then undergoes operational cycles at 100 per cent NWP (+2/-0MPa) through 5 per cent of the total cycles with the part stabilized at -40°C or lower. At the completion of the -40°C operational cycles, the unit shall comply with the low temperature (-40°C) leak test specified in 2.2.2.
- (c) Check valve chatter flow test: Following 11,000 operational cycles and leak tests in 2.2.3.(b), the check valve is subjected to 24 hours of chatter flow at a flow rate that causes the most chatter (valve flutter). At the completion of the test the check valve shall comply with the ambient temperature leak test (2.2.2.) and the strength test (2.2.1.).

2.2.4. Salt corrosion resistance test

The component is supported in its normally installed position and exposed for 500 hours to a salt spray (fog) test as specified in ASTM B117 (standard practice for operating salt spray (fog) apparatus). The temperature within the fog chamber is maintained at 30-35 °C). The saline solution consists of 5 per cent sodium chloride and 95 per cent distilled water, by weight.

Immediately after the corrosion test the sample is rinsed and gently cleaned of salt deposits, examined for distortion, and then shall comply with the requirements of:

- (a) The component must now show signs of physical degradation that could impair the function of the component, specifically: cracking, softening or swelling. Cosmetic changes such as pitting or staining are not failures:
- (b) The ambient temperature leak test (2.2.2.);
- (c) The hydrostatic strength test (2.2.1.).

2.2.5. Vehicle environment test

Resistance to degradation by exposure to automotive fluids is determined by the

following test.

- (a) The inlet and outlet connections of the valve unit are connected or capped in accordance with the manufacturers installation instructions. The external surfaces of the valve unit are exposed for 24 hours at 20 (± 5) °C to each of the following fluids:
 - (i) Sulphuric acid - 19 per cent solution by volume in water;
 - (ii) Sodium hydroxide - 25 per cent solution by weight in water,
 - (iii) Ammonium nitrate - 28 per cent by weight in water, and
 - (iv) Windshield washer fluid (50 per cent by volume methyl alcohol and water).

The fluids are replenished as needed to ensure complete exposure for the duration of the test.

A distinct test is performed with each of the fluids. One component may be used for exposure to all of the fluids in sequence.

- (b) After exposure to each chemical, the component is wiped off and rinsed with water;
- (c) The component shall not show signs of physical degradation that could impair the function of the component, specifically: cracking, softening, or swelling. Cosmetic changes such as pitting or staining are not failures. At the conclusion of all exposures, the unit(s) shall comply with the requirements of the ambient temperature leakage test (2.2.2.) and hydrostatic strength test (2.2.1.).

2.2. Atmospheric exposure test

The atmospheric exposure test applies to qualification of check valve and automatic shut-off valves if the component has non-metallic materials exposed to the atmosphere during normal operating conditions.

- (a) All non-metallic materials that provide a fuel containing seal, and that are exposed to the atmosphere, for which a satisfactory declaration of properties is not submitted by the applicant, shall not crack or show visible evidence of deterioration after exposure to oxygen for 96 hours at 70°C at 2 MPa in accordance with ASTM D572 (standard test method for rubber-deterioration by heat and oxygen); (b)
- (b) All elastomers shall demonstrate resistance to ozone by one or more of the following:
 - (i) Specification of elastomer compounds with established resistance to ozone;
 - (ii) Component testing in accordance with ISO 1431/1, ASTM D1149, or equivalent test methods.

2.2.7. Electrical Tests

The electrical tests apply to qualification of the automatic shut-off valve; they do not apply to qualification of check valves

- (a) Abnormal voltage test. The solenoid valve is connected to a variable DC voltage source. The solenoid valve is operated as follows:
 - (i) An equilibrium (steady state temperature) hold is established for one hour at 1.5 times the rated voltage;
 - (ii) The voltage is increased to two times the rated voltage of 60 volts, whichever is less, and held for one minute;
 - (iii) Any failure shall not result in external leakage, open valve or unsafe conditions such as smoke, fire or melting.
- (b) The minimum opening voltage at NWP and room temperature shall be less than or equal to 9V for a 12 V system and less than or equal to 18 V for a 24V system. Insulation resistance test. 1,000 V D.C. is applied between the power conductor and the component casing for at least two seconds. The minimum allowable resistance for that component is 240 k Ω .

2.2.8. Vibration test

The valve unit is pressurized to its 100 per cent NWP (+2/-0MPa) with hydrogen, sealed at both ends, and vibrated for 30 minutes along each of the three orthogonal axes (vertical, lateral and longitudinal) at the most severe resonant frequencies. The most severe resonant frequencies are determined by acceleration of 1.5 g with a sweep time of 10 minutes within a sinusoidal frequency range of 10 to 40Hz. If the resonance frequency is not found in this range the test is conducted at 40Hz. Following this test, each sample shall not show visible exterior damage that indicates that the performance of the part is compromised. At the completion of the test, the unit shall comply with the requirements of the ambient temperature leak test specified in 2.2.2.

2.2.9. Stress corrosion cracking test

For the valve units containing components made of a copper-based alloy (e.g. brass), one valve unit is tested.

The valve unit is disassembled, all copper-based alloy components are degreased and

then the valve unit is reassembled before it is continuously exposed for ten days to a moist ammonia-air mixture maintained in a glass chamber having a glass cover.

Aqueous ammonia having a specific gravity of 0.94 is maintained at the bottom of the glass chamber below the sample at a concentration of at least 20 ml per litre of chamber volume. The sample is positioned 35(±5) mm above the aqueous ammonia solution and supported in an inert tray. The moist ammonia-air mixture is maintained at atmospheric pressure at 35(±5) °C. Copper-based alloy components shall not exhibit cracking or delaminating due to this test.

2.2.10. Pre-cooled hydrogen exposure test

The valve unit is subjected to pre-cooled hydrogen gas at -40 °C or lower at a flow rate of 30 g/s at external temperature of 20 (±5) °C for a minimum of three minutes. The unit is de pressurized and re-pressurized after a two minute hold period. This test is repeated ten times. This test procedure is then repeated for an additional ten cycles, except that the hold period is increased to 15 minutes. The unit shall then comply with the requirements of the ambient temperature leak test specified in 2.2.2.

3. Test procedures for electrical safety (5.3.)

3.1. Isolation resistance measurement method

3.1.1. General

The isolation resistance for each high voltage bus of the vehicle is measured or shall be determined by calculating the measurement values of each part or component unit of a high voltage bus (hereinafter referred to as the "divided measurement").

3.1.2. Measurement method

The isolation resistance measurement is conducted by selecting an appropriate measurement method from among those listed in paras. 3.1.2.1. to 3.1.2.2., depending on the electrical charge of the live parts or the isolation resistance.

The range of the electrical circuit to be measured is clarified in advance, using electrical circuit diagrams. Moreover, modifications necessary for measuring the isolation resistance may be carried out, such as removal of the cover in order to reach the live parts, drawing of measurement lines and change in software.

In cases where the measured values are not stable due to the operation of the on-

board isolation resistance monitoring system, necessary modifications for conducting the measurement may be carried out by stopping the operation of the device concerned or by removing it. Furthermore, when the device is removed, a set of drawings will be used to prove that the isolation resistance between the live parts and the electrical chassis remains unchanged.

Utmost care shall be exercised to avoid short circuit and electric shock since this confirmation might require direct operations of the high-voltage circuit.

3.1.2.1. Measurement method using DC voltage from off-vehicle sources

3.1.2.1.1. Measurement instrument

An isolation resistance test instrument capable of applying a DC voltage higher than the working voltage of the high voltage bus is used.

3.1.2.1.2. Measurement method

An insulator resistance test instrument is connected between the live parts and the electrical chassis. The isolation resistance is subsequently measured by applying a DC voltage at least half of the working voltage of the high voltage bus.

If the system has several voltage ranges (e.g. because of boost converter) in conductive connected circuit and some of the components cannot withstand the working voltage of the entire circuit, the isolation resistance between those components and the electrical chassis can be measured separately by applying their own working voltage with those components disconnected.

3.1.2.2. Measurement method using the vehicle's own REESS as DC voltage source

3.1.2.2.1. Test vehicle conditions

The high voltage-bus is energized by the vehicle's own REESS and/or energy conversion system and the voltage level of the REESS and/or energy conversion system throughout the test shall be at least the nominal operating voltage as specified by the vehicle manufacturer.

3.1.2.2.2. Measurement instrument

The voltmeter used in this test shall measure DC values and has an internal resistance of at least 10 M Ω .

3.1.2.2.3. Measurement method

3.1.2.2.3.1. First step

The voltage is measured as shown in Figure 9 and the high voltage Bus voltage (V_b) is recorded. V_b shall be equal to or greater than the nominal operating voltage of the REESS and/or energy conversion system as specified by the vehicle manufacturer.

Figure 8

Measurement of V_b , V_1 , V_2

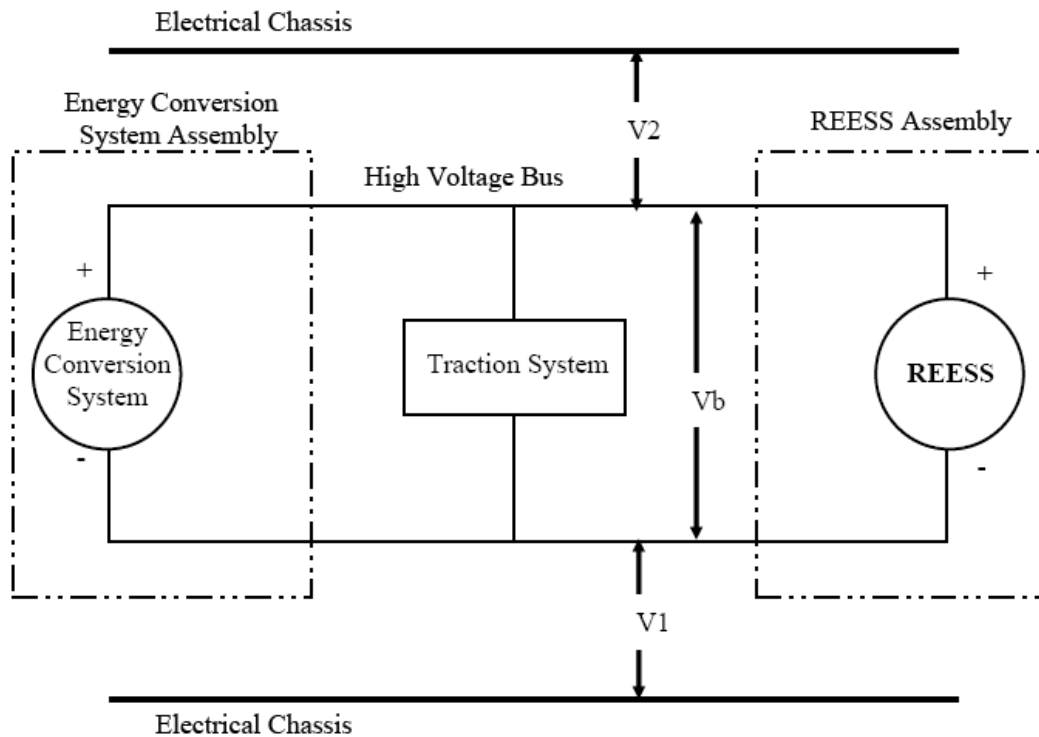

3.1.2.2.3.2. Second step

The voltage (V_1) between the negative side of the high voltage bus and the electrical chassis is measured and recorded (see Figure 8).

3.1.2.2.3.3. Third step

The voltage (V_2) between the positive side of the high voltage bus and the electrical

chassis is measured and recorded (see Figure 8).

3.1.2.2.3.4. Fourth step

If V_1 is greater than or equal to V_2 , a standard known resistance (R_0) is inserted between the negative side of the high voltage bus and the electrical chassis. With R_0 installed, the voltage (V_1) between the negative side of the high voltage bus and the electrical chassis is measured (see Figure 9). The electrical isolation (R_i) is calculated according to the following formula:

$$R_i = R_0 \cdot \frac{V_b}{V_1} - \frac{V_b}{V_1} \quad (\text{or } R_i = R_0 \cdot \frac{V_b}{V_1} - 1) \cdot \frac{1}{V_1}$$

The resulting R_i , which is the electrical isolation resistance value (in Ω), is divided by the working voltage of the high voltage bus in volt (V):

$$R_i \Omega / V = R_i \Omega / \text{Working voltage (V)}$$

Figure 9

Measurement of V_1

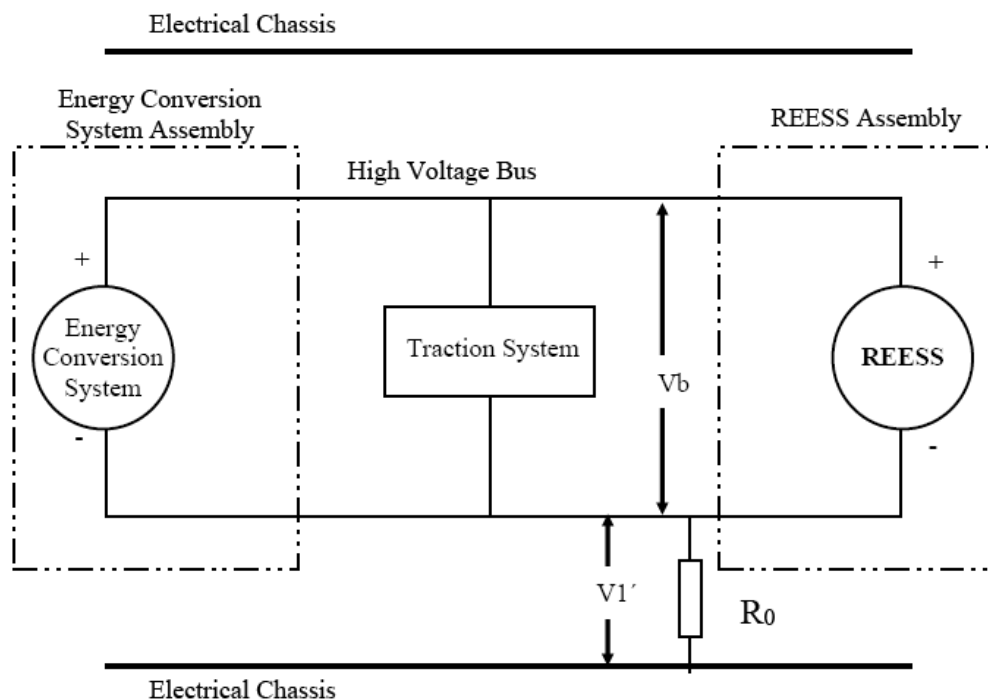

If V_2 is greater than V_1 , a standard known resistance (R_0) is inserted between the positive side of the high voltage bus and the electrical chassis. With R_0 installed, the voltage (V_2) between the positive side of the high voltage bus and the electrical chassis is measured

(see Figure 10). The electrical isolation (RI) is calculated according to the formula shown below. This electrical isolation value (in ohms) is divided by the nominal operating voltage of the high voltage bus (in volts). The electrical isolation (Ri) is calculated according to the following formula:

$$R_i = R_o \cdot \left(\frac{V_b}{V_2'} - \frac{V_b}{V_2} \right) \quad \text{(or } R_i = R_o \cdot V_b \cdot \left(\frac{1}{V_2'} - \frac{1}{V_2} \right) \text{)}$$

The resulting Ri, which is the electrical isolation resistance value (in), is divided by the working voltage of the high voltage bus in volts (V).

$$R_i \, \Omega / V = R_i \, \Omega / \text{Working voltage}$$

Figure 10

Measurement of V2

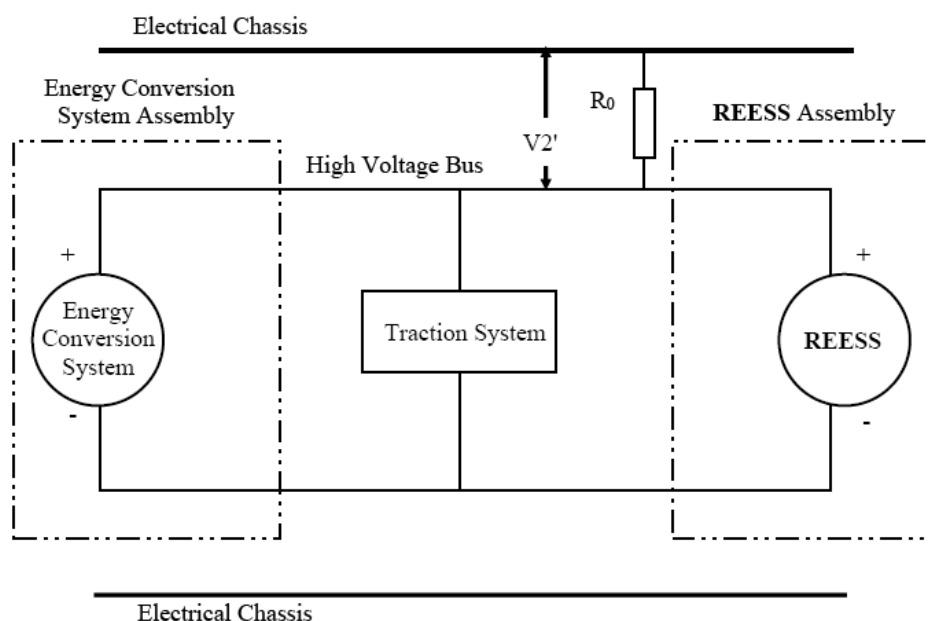

3.1.2.2.3.5. Fifth step

The electrical isolation value Ri (in ohms) divided by the working voltage of the high voltage bus (in volts) results in the isolation resistance (in ohms/volt).

(Note 1: The standard known resistance Ro (in ohms) is the value of the minimum required isolation resistance (in ohms/6) multiplied by the working voltage of the vehicle plus/minus 20 per cent (in volts). Ro is not required to be precisely this value since the equations are valid for any Ro; however, a Ro value in this range should

provide good resolution for the voltage measurements.)

3.2. Confirmation Method for Functions of On-board Isolation Resistance Monitoring System

The function of the on-board isolation resistance monitoring system is confirmed by the following method or a method equivalent to it.

A resistor is inserted that does not cause the isolation resistance between the terminal being monitored and the electrical chassis to drop below the minimum required isolation resistance value. The warning signal shall be activated.

3.3. Protection against direct contacts of parts under voltage

3.3.1. Access probes

Access probes to verify the protection of persons against access to live parts are given in Table 3.

3.3.2. Test conditions

The access probe is pushed against any openings of the enclosure with the force specified in Table 3. If it partly or fully penetrates, it is placed in every possible position, but in no case shall the stop face fully penetrate through the opening.

Internal electrical protection barriers are considered part of the enclosure.

A low-voltage supply of not less than 40 V and not more than 50 V) in series with a suitable lamp is connected, if necessary, between the probe and live parts inside the electrical protection barrier or enclosure.

The signal-circuit method is also applied to the moving live parts of high voltage equipment.

Internal moving parts may be operated slowly, where this is possible.

3.3.3. Acceptance conditions

The access probe shall not touch live parts.

If this requirement is verified by a signal circuit between the probe and live parts, the lamp shall not light.

In the case of the test for IPXXB, the jointed test finger may penetrate to its 80 mm length, but the stop face (diameter 50 mm x 20 mm) shall not pass through the opening. Starting from the straight position, both joints of the test finger are successively bent through an angle of up to 90 degree with respect to the axis of the

adjoining section of the finger and are placed in every possible position.

In case of the tests for IPXXD, the access probe may penetrate to its full length, but the stop face shall not fully penetrate through the opening.

Table 3

Access probes for the tests for protection of persons against access to hazardous parts

First numeral	Addit. letter	Access probe (Dimensions in mm)	Test force
2	B	<p>Jointed test finger</p> <p>See Fig.1 for full dimensions</p> <p>Insulating material</p> <p>Stop face (Ø 50 x 20)</p> <p>Ø 12</p> <p>Jointed test finger (Metal)</p> <p>80</p>	10 N±10%
4, 5, 6	D	<p>Test wire 1.0 mm diameter, 100 mm long</p> <p>Ø 10</p> <p>Approx. 100</p> <p>Sphere 35±0.2</p> <p>100±0.2</p> <p>Ø 1 +0.05/0</p> <p>Handle (Insulating material)</p> <p>Stop face (Insulating material)</p> <p>Rigid test wire (Metal)</p> <p>Edges free from burrs</p>	1N±10%

Figure 11
Jointed Test Fingers

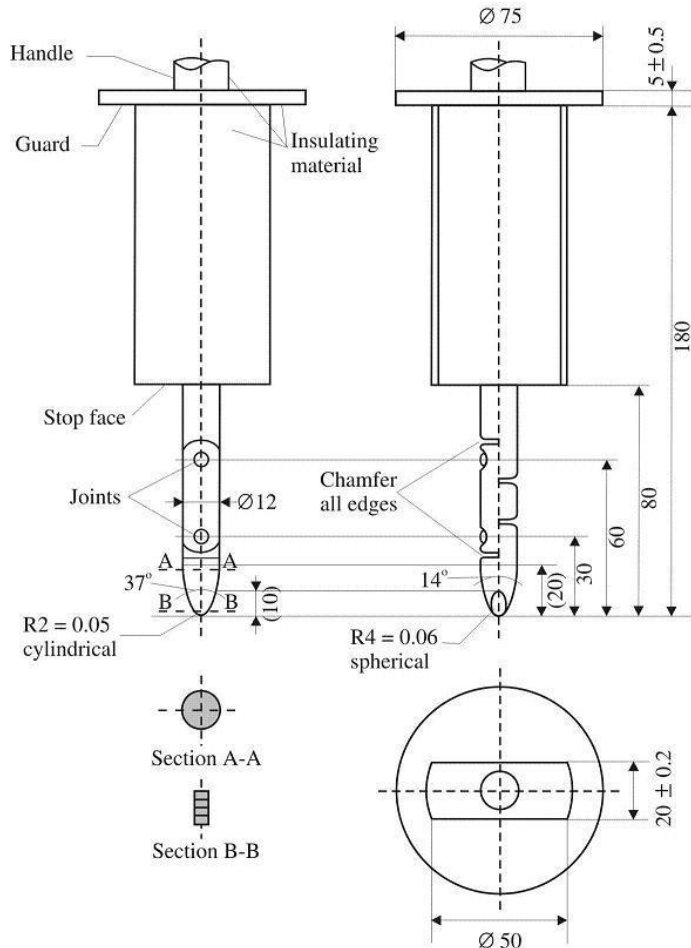

Material: metal, except where otherwise specified

Linear dimensions in millimetres

Tolerances on dimensions without specific tolerance:

on angles, 0/10'

on linear dimensions:

up to 25 mm: 0/-0.05

over 25 mm: ±0.2

Both joints shall permit movement in the same plane and the same direction through an angle of 90° with a 0 to +10° tolerance.

3.4 Test Method for Measuring Electric Resistance

Test method using a resistance tester.

The resistance tester is connected to the measuring points (typically, electrical chassis and electro conductive enclosure/electrical protection barrier) and the resistance is measured using a resistance tester that meets the specification that follows;

Resistance tester: Measurement current at least 0.2 A

Resolution 0.01 Ω or less

The resistance R shall be less than 0.1 ohm.

Test method using D.C. power supply, voltmeter and ammeter.

Example of the test method using D.C. power supply, voltmeter and ammeter is shown below.

Figure 12

Connection to Barrier/Enclosure

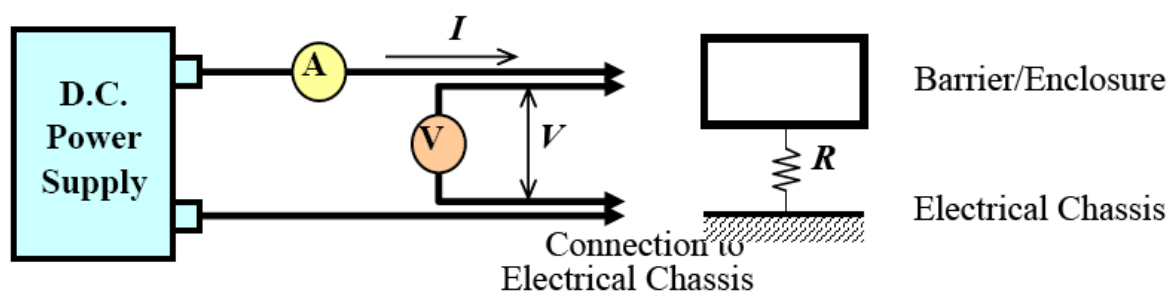

Test Procedure

The D.C. power supply, voltmeter and ammeter are connected to the measuring points (Typically, electrical chassis and electro conductive enclosure/electrical protection barrier).

The voltage of the D.C. power supply is adjusted so that the current flow becomes more than 0.2 A.

The current "I" and the voltage "V" are measured.

The resistance "R" is calculated according to the following formula: $R=V/I$

The resistance R shall be less than 0.1 ohm.

Note. If lead wires are used for voltage and current measurement, each lead wire shall be independently connected to the electrical protection barrier/enclosure/electrical chassis.

Terminal can be common for voltage measurement and current measurement.

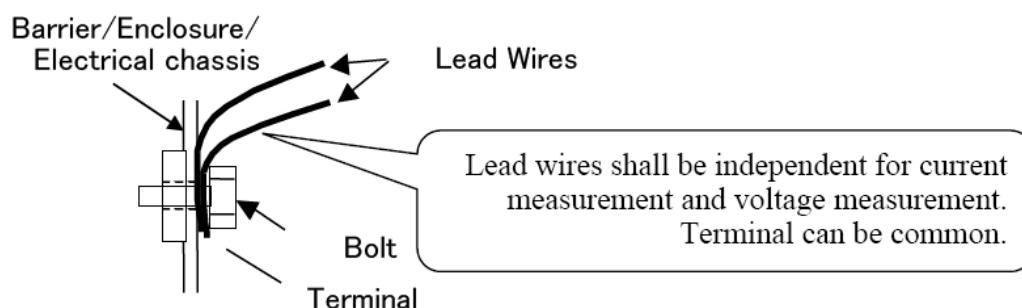

3.5 Test Conditions and Test Procedure regarding Post Crash

3.5.1. Test Conditions

3.5.1.1. General

The test conditions specified in paragraphs 3.5.1.2 to 3.5.1.4. are used.

Where a range is specified, the vehicle shall be capable of meeting the requirements at all points within the range

3.5.1.2. Electrical power train adjustment

3.5.1.2.1. The REESS may be at any state of charge, which allows the normal operation of the power train as recommended by the manufacturer.

3.5.1.2.2. The electrical power train shall be energized with or without the operation of the original electrical energy sources (e.g. engine-generator, REESS or electric energy conversion system), however:

3.5.1.2.2.1. It is permissible to perform the test with all or parts of the electrical power train not being energized insofar as there is no negative influence on the test result. For parts of the electrical power train not energized, the protection against electric shock shall be proved by either physical protection or isolation resistance and appropriate additional evidence.

3.5.1.2.2.2. If the power train is not energized and an automatic disconnect is provided, it is permissible to perform the test with the automatic disconnect being triggered. In this case it shall be demonstrated that the automatic disconnect would have operated during the impact test. This includes the automatic activation signal as well as the

conductive separation considering the conditions as seen during the impact.

3.5.1.3. Contracting parties may allow modifications to the fuel system so that an appropriate amount of fuel can be used to run the engine or the electrical energy conversion system.

3.5.1.4. The vehicle conditions other than specified in paras. 3.5.1.1. to 3.5.1.3. are in the crash test protocols of the contracting parties.

3.5.2. Test Procedures for the protection of the occupants of vehicles operating on electrical power from high voltage and electrolyte spillage This section describes test procedures to demonstrate compliance with the electrical safety requirements of 5.3.2.

Before the vehicle impact test conducted, the high voltage bus voltage (V_b) (see Figure 13) is measured and recorded to confirm that it is within the operating voltage of the vehicle as specified by the vehicle manufacturer.

3.5.2.1. Test setup and equipment

If a high voltage disconnect function is used, measurements are taken from both sides of the device performing the disconnect function.

However, if the high voltage disconnect is integral to the REESS or the energy conversion system and the high-voltage bus of the REESS or the energy conversion system is protected according to protection degree IPXXB following the impact test, measurements may only be taken between the device performing the disconnect function and electrical loads.

The voltmeter used in this test measures DC values and have an internal resistance of at least $10\text{ M}\Omega$.

3.5.2.2. The following instructions may be used if voltage is measured.

After the impact test, determine the high voltage bus voltages (V_b , V_1 , V_2) (see figure 13).

The voltage measurement is made no earlier than 5 seconds, but not later than 60 seconds after the impact.

This procedure is not applicable if the test is performed under the condition where the electric power train is not energized.

Figure 13

Measurement of V_b , V_1 , V_2

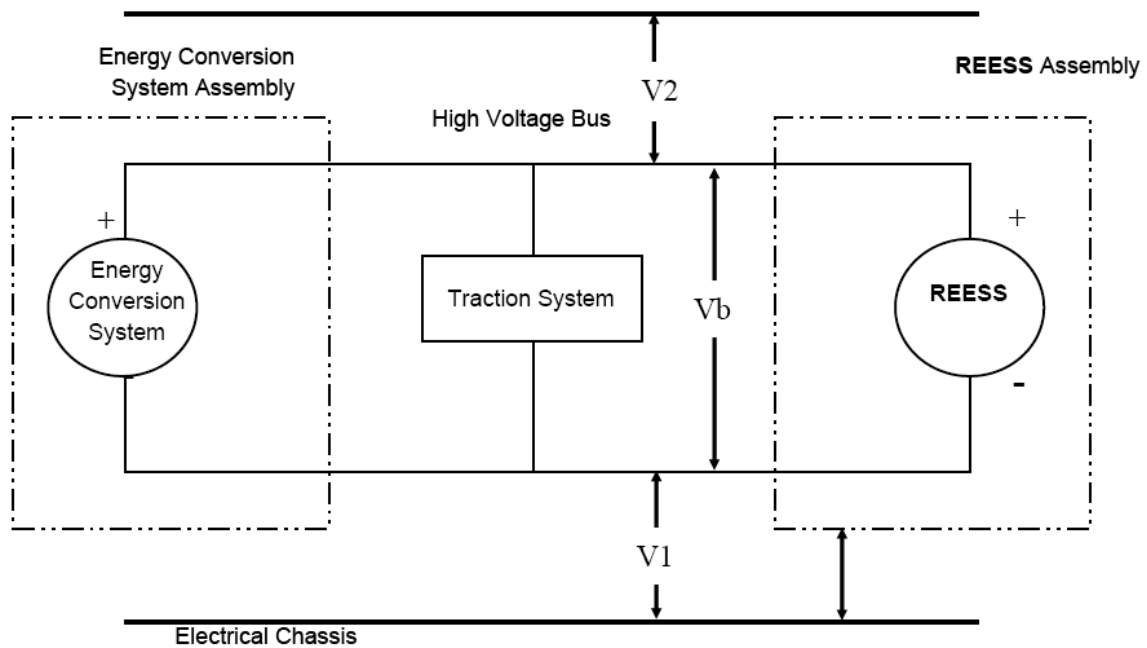

3.5.2.3. Isolation resistance

See 3.1.2. "Measurement method"

All measurements for calculating voltage(s) and electrical isolation are made after a minimum of 5 seconds after the impact.

For example, megohmmeter or oscilloscope measurements are an appropriate alternative to the procedure described above for measuring isolation resistance. In this case it may be necessary to deactivate the on-board isolation resistance monitoring system.

3.5.2.4. Physical Protection

Following the vehicle crash test, any parts surrounding the high voltage components are opened, disassembled or removed without the use of tools. All remaining surrounding parts shall be considered part of the physical protection.

The jointed test finger described in 3.3. is inserted into any gaps or openings of the physical protection with a test force of 10 N \pm 10 per cent for electrical safety assessment. If partial or full penetration into the physical protection by the Jointed Test Finger occurs, the Jointed Test Finger shall be placed in every position as specified

below.

Starting from the straight position, both joints of the test finger are rotated progressively through an angle of up to 90 degrees with respect to the axis of the adjoining section of the finger and are placed in every possible position.

Internal electrical protection barriers are considered part of the enclosure

If appropriate, a low-voltage supply (of not less than 40 V and not more than 50 V) in series with a suitable lamp is connected between the Jointed Test Finger and high voltage live parts inside the electrical protection barrier or enclosure

3.5.2.5. Acceptance conditions

The requirements of 5.3.2.2.3. are met if the jointed test finger described in 3.3. is unable to contact high voltage live parts.

If necessary, a mirror or a fibre scope may be used in order to inspect whether the jointed test finger touches the high voltage buses.

If this requirement is verified by a signal circuit between the jointed test finger and high voltage live parts, the lamp shall not light.

3.5.2. Electrolyte spillage

Appropriate coating shall be applied, if necessary, to the physical protection in order to confirm any electrolyte leakage from the REESS after the impact test.

Unless the manufacturer provides the means to differentiate among the leakage of different liquids, all liquid leakage is considered as an electrolyte.

3.5.2.7. REESS retention

Compliance shall be determined by visual inspection